

# Plumber™



## UNRIVALED POWERED ANODE ROD CORRO-PROTEC

**HASSLE-FREE  
HOT WATER**



**ELIMINATES SULFUR  
SMELL IN HOT WATER**



**STOPS CORROSION  
INSIDE TANK**



*SCAN THIS OR SEE  
INSIDE TO LEARN MORE  
ABOUT CORRO-PROTEC*



PRSTD STD  
U.S. POSTAGE  
PAID  
COLE  
PUBLISHING INC

ELECTRONIC SERVICE REQUESTED

COLE PUBLISHING INC.  
PO BOX 220  
THREE LAKES WI 54562

# AMAZON #1 BEST SELLER IN WATER HEATERS & PARTS

JOIN THE BEST &  
TRY CORRO-PROTEC!

## ⚡ POWERED ANODE ROD

REDEEM YOUR **FREE TRIAL KIT**  
& BECOME A RESELLER

INCLUDES OUR US \$159  
POWERED ANODE ROD



geni.us/try-it



**REDUCES** SCALING &  
SEDIMENT ACCUMULATION



**ELIMINATES** SULFUR  
SMELL IN HOT WATER



**STOPS** CORROSION &  
PREVENTS CLOUDY WATER

## LITTLE CURRENT. HUGE BENEFITS.

Corro-Protec is disrupting the water heater industry with its new generation of **Powered Anode Rods** made of titanium, which are much more effective than traditional magnesium and aluminum/zinc rods.

**20** YEAR  
WARRANTY

WE MANAGE ALL  
CUSTOMER SERVICE!

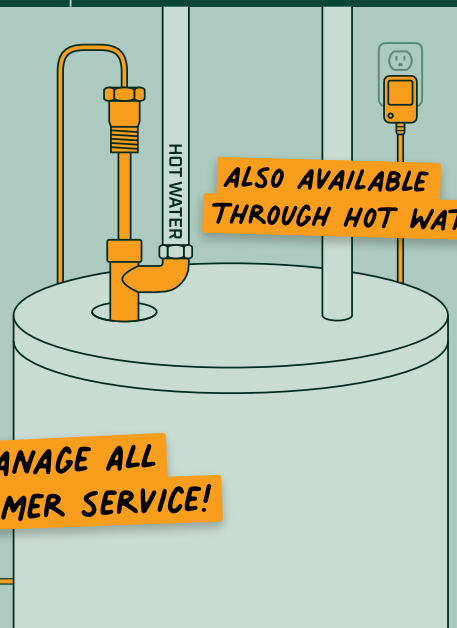

# Plumber<sup>TM</sup>

**BUYER'S  
GUIDE**  
page 28

## Learning from **HISTORY**

Third-generation owner uses data-driven strategies to help shape a family business evolution. **Page 12**

▲ **Smart Business**  
SIMPLE APPROACHES WILL HELP  
BRING CUSTOMERS BACK  
**Page 24**

▲ **Industry Insider**  
TRAINING AND MENTORSHIPS  
NEED TO HAPPEN TO BRING  
MORE INTO INDUSTRY  
**Page 26**

MACHINES  
THAT WORK  
AS HARD  
AS YOU DO



OFTEN IMITATED  
NEVER  
DUPLICATED



MODEL 727



MODEL 100



MODEL 1065



MODEL 300



MODEL 717

**You need tools you can count on to get the job done.**

Only one name in the industry is known for tools that don't quit, even after quitting time. Spartan Tool is proud to outfit the toughest professionals in the industry who rely on our machines to get to job done, time after time.

payments as low as

**\$97**  
per month\*



SCAN ME

**Work now, pay later.**

Work now, pay later with payments as low as \$97 per month on cable machine packages and cart jettors from Spartan Tool. Start making money immediately when you finance your cable machine package through our partners at Apex Commercial Capital.

*\*Prices before tax and shipping. Subject to credit approval.*

**SPARTANTOOL.COM**  
**800.435.3866**

# ULTIMATE DRAIN CLEANING BUSINESS PACKAGE

SYSTEMS  
Indus...com  
DRAINLINE JETTING EQUIPMENT  
www.hotjetusa.com  
4-8186

FOR CURRENT  
PRICING & AVAILABILITY  
**CONTACT US  
TODAY!**



Featuring the

## HOTJET II<sup>®</sup>

BUILT FOR THE PLUMBER

\*TRAINING INCLUDED!

# NOW

IS THE  
TIME TO  
GROW YOUR BUSINESS

Package also includes:

### Hand-Held Jetter



- 120v/2HP Premium Baldor Motor
- 2 GPM 1600 PSI Adjustable Pressure
- Ball Valve On and Off
- HD Frame and Tires
- 100' 1/4" Jetting Hose
- Lazer & Ram Nozzles Included

### Inspection Camera



- Complete Package, Turn Key Ready to Use
- Extended Warranty (2 Years)
- No Up-Selling
- \$490 Bonus Value Product Included
- Comes with 2nd Head to Inspect Smaller Lines

### Utility Locator



- 33kHz or 512Hz Operating Frequency
- Antenna Mode: Peak
- Continuous Battery Life: 40 hours
- Backlit LCD Bar Graph & Indicators
- Variable Pitch Response
- 126dB Dynamic Range

  
**HotJetUSA<sup>®</sup>**

# 1-800-624-8186



\*Training includes flight (from lower 48 states only) to our training facility in Salt Lake City, hotel, ground transportation and meals for one. Please contact us for freight costs. HotJet USA ships international.



# 12

Plumber  
**Profile**

## Learning from History

Third-generation owner uses data-driven strategies to help shape a family business evolution.

- By Ken Wysocky



## On the Cover

Plumber Dan Thomas, with Agentis Plumbing, turns valves off at a residential site in Bethlehem, Pennsylvania, in preparation of replacing thermal expansion tanks. Agentis Plumbing, owned by Nate Agentis, was founded in 1954 by Nate's grandfather. The company now has 60 employees and works a 40-mile radius around Bethlehem.

(Photography by Hannah Beier)

## 8 From the Editor: Navigating the Data Pipeline

Tracking all sorts of information from calls to time on a job can help your plumbing company in many different ways.

- By Cory Dellenbach

## 10 @plumbermag.com

Check out our exclusive online content.

## 20 In the Shop: Unlocking the Power of AI

A guide for home service businesses to navigate the emerging artificial intelligence age.

- By Katie Donovan

## 24 Smart Business: Unraveling Complexity

Simpler approaches to serving customers will improve their experience, encourage them to call again and again.

- By Kate Zabriskie

## 26 Industry Insider: What It Takes to be a Plumber

As workforce gets older, there needs to be a call for proper training and mentorship in the trade.

- By Ken Dickerson

## 28 Annual Buyer's Guide

## 64 On The Road: Mastering the Craft

Tips to taking care of your daily-used tools so they last a long time for you and your team.

- By Cory Dellenbach

## 66 Product News: Product Spotlight: Hydronic radiant heating system is clean, efficient and green

- By Cody Wiesner

## 71 Calendar

## 74 Industry News

### Coming Next Month - Residential Plumbing/ Water Quality and Conditioning

- ▲ Plumber Profile: Kyle's Plumbing (Deerfield Beach, Florida)
- ▲ Industry Insider: Anthony Pacilla

# **R-8** Pipe Bursting System



**RODDIE** inc.

- Unit slides apart quickly into two components for easy handling and can be set up vertically or horizontally.
- Hydraulically powered by your tractor, or power unit.
- 1" - 8" pipe replacement
- Cylinders 70lbs.
- Frame 70lbs.



**DIMENSIONS:**  
14" long by 12" wide  
22" high set vertically

















**See it Work!**

 **YouTube**  
**Roddie R-8**

**888-406-3821**

Patent Pending • [RoddieUnderground.com](http://RoddieUnderground.com)

# ADVERTISER INDEX

ACME Trenchless .....	67	Legend Valve .....	17
<b>ALLAN J. COLEMAN</b> SINCE 1905		Liberty Pumps.....	41
Allan J. Coleman Co.....	11	<b>LittleGIANT</b>	
American Jetter .....	73	Little Giant .....	35
Aqua-Rex LLC .....	27		
		MaxLiner .....	75
AQUAGUARD LLC .....	51		
Arcan Enterprises.....	73	Mongoose Jetters by Sewer Equipment .....	39
		<b>MyTana</b>	
Ashland Pump.....	53	MyTana LLC .....	61
		<b>nuFlow</b>	
Bradford White Water Heaters.....	47	WE FIX PIPES NuFlow Technologies.....	37
		Oatev Co.....	45
Cam Spray.....	15		
		Picote Solutions .....	69
Central Oklahoma Winnelson.....	49	Pipeline Renewal Technologies .....	65
Crane Pumps & Systems.....	23	PIER Products .....	25
Cua Claws for Resurfacing Camera Wheels .....	73	<b>PROGRESSIVE</b> COMMERCIAL	
Dallas Specialty & Mfg. Co.....	51	Progressive Insurance .....	19
			
Duracable Manufacturing Co.....	43	Pulsar 2000 Line Tracer .....	21
Duravit USA, Inc.....	9	Pulsar 2000, Inc. ....	21
Easy-Kleen Pressure Systems Ltd.....	67	Qescorp d/b/a DiscountSawBlade.com.....	71
ENPRESS LLC .....	22	RauschUSA .....	55
<b>FASTEST, INC.</b> Mechanical Estimating Software		<b>Roddie</b> Inc.	
FastEST, Inc.....	69	Roddie Inc .....	5
FORMADRAIN .....	31	Root Rat .....	73
<b>General PIPE CLEANERS</b>		SalesMaker Carts.....	65
General Pipe Cleaners, div. of General Wire Spring.....	76		
		SPARTAN TOOL Spartan Tool LLC .....	2
HammerHead Trenchless .....	33		
Heat-flo .....	57	Superior Signal Company LLC .....	73
Hermann Sewerin GmbH.....	49		
		SuppliesDepot.com .....	7
HotJet USA.....	3, 73	Vivax-Metrotech Corp.....	53
		Walton Company .....	71
IPP Solutions, LLC.....	59	Classifieds .....	73

# Plumber

Exclusively serving plumbing contractors and franchisees

Published monthly by COLE Publishing, Inc.  
P.O. Box 220, Three Lakes, WI 54562

Call toll-free 800-257-7222  
Mon.- Fri., 7:30 a.m.-5 p.m. CST

Website: [www.plumbermag.com](http://www.plumbermag.com)  
Email: [info@plumbermag.com](mailto:info@plumbermag.com) | Fax: 715-350-8456

**SUBSCRIPTION INFORMATION:** A one-year (12-issue) subscription to Plumber in the United States or Canada is free to qualified subscribers. A qualified subscriber is any individual or company in the United States or Canada that is involved in the inspection, cleaning, repair and installation of residential and commercial sewer lines. Non-qualified subscriptions are available at a cost of \$60 per year in the United States and Canada/Mexico. Subscriptions to all other foreign countries cost \$80 per year. To qualify, visit [www.plumbermag.com/order/subscription](http://www.plumbermag.com/order/subscription) or call 800-257-7222.

Our subscriber list is occasionally made available to carefully selected companies whose products or services may be of interest to you. Your privacy is important to us. If you prefer not to be a part of these lists, please contact Holly at [holly.gensler@colepublishing.com](mailto:holly.gensler@colepublishing.com).

**CLASSIFIED ADVERTISING; RATE:** No Photo Classified \$25 for 20 words, each additional word \$1. All classified advertising must be PAID IN ADVANCE. DEADLINE: Classifieds must be received by the first of the month for insertion in the next month's edition. PHONE-IN ADS ARE NOT ACCEPTED. Ads may be faxed only when charging to MasterCard, VISA, Amex or Discover. Please supply all credit card information with faxed ads. Be sure to include your phone number (with area code) in your ad. Make checks payable to COLE Publishing Inc. and mail with classified ad to the address above. CLASSIFIED ADVERTISING APPEARS NATIONWIDE AND ON THE INTERNET. Not responsible for errors beyond first insertion.

**DISPLAY ADVERTISING:**

Contact one of our sales staff at 800-994-7990. Publisher reserves the right to reject advertising that in its opinion is misleading, unfair or incompatible with the character of the publication.



Ann Richmond



Winnie May

**DIGITAL REPRINTS AND BACK ISSUES:** Visit [www.plumbermag.com](http://www.plumbermag.com) for digital reprint options and pricing. To order back issues, call Holly at 800-257-7222 or email [holly.gensler@colepublishing.com](mailto:holly.gensler@colepublishing.com).

**CONTROLLED CIRCULATION:** 22,000 per month  
This figure includes both U.S. and international distribution.

© 2024 COLE PUBLISHING INC.

No part may be reproduced without permission of the publisher.

-  [facebook.com/PlumberMag](https://facebook.com/PlumberMag)
-  [twitter.com/PlumberMag](https://twitter.com/PlumberMag)
-  [youtube.com/PlumberMagazine](https://youtube.com/PlumberMagazine)
-  [linkedin.com/company/plumber-magazine](https://linkedin.com/company/plumber-magazine)
-  [instagram.com/plumber.mag](https://instagram.com/plumber.mag)

**Plumber** *It's your Magazine. Tell your story.*

Send your ideas for future articles to [editor@plumbermag.com](mailto:editor@plumbermag.com)





# SuppliesDepot.com

Your Source for Plumbing, Heating, Electrical and Lighting Products.



## HVAC OEM REPAIR PARTS

IN STOCK & READY TO SHIP!

**Thousands of OEM Parts in Stock from Top Brands**



**Goodman**



**WEIL-McLAIN**



**UTICA  
BOILERS**



**NAVIEN**

**Rinnai** *Raypak*



**AC Smith**



**BRADFORD WHITE**

*and more!*



**Take 5% OFF Your Order of \$250 & Up**  
**Use Coupon Code SDJUNE5**

\*Exclusions apply. Coupon Offer valid 6/1/24 to 6/30/24 only. See website for details.



Cory Dellenbach

## Navigating the Data Pipeline

Tracking all sorts of information from calls to time on a job can help your plumbing company in many different ways

**I** have a bad habit and that habit is keeping data on everything that I am involved in. As an example, my entire family is involved in bowling with the kids on the middle and high school team here in our community and my wife and I both in adult leagues.

I track all of our data. I keep track of our scores, what spares we leave, how we do on spare pickups and fill-percentages (getting strikes and spares and leaving open frames). I love tracking that data and seeing — hopefully — improvement as the season goes along.

I do that with other activities too. Tracking website data for the local water ski team's website that I help with, and church attendance numbers, and so on. Let's just say ... I like data collection.

It's really not a bad thing. It does help. For example, I look at the bowling data and I can see what my kids are missing out there with spares and help them adjust to start picking those up.

Nick Agentis, owner of Agentis Plumbing in Pennsylvania, is kind of the same way with data collection. As you'll read in this issue's profile on the company, that data collection helps him determine what to do with his company.

### USING THE DATA

In today's digital age, data has become the cornerstone of innovation, driving decision-making processes across industries, including plumbing. As plumbers, you might wonder how data fits into your world of pipes and wrenches. Data is not just for tech companies or marketers — it's a powerful tool that can revolutionize the way you work and serve your customers.

Tracking data in the plumbing industry is not about monitoring website clicks or social media engagement. Instead, it's about using information to optimize operations, enhance customer service and stay ahead of the curve in a rapidly evolving landscape.

Agentis Plumbing, as you'll read, uses a management software that provides a dashboard for every position on the team. That dashboard tells them their leading and lagging metrics and tells when they've beaten or missed goals.

By analyzing historical data on job durations, customer demand and technician availability, you can optimize your workflow to minimize downtime and maximize productivity. This not only boosts your bottom line, but also enhances customer satisfaction by ensuring timely service delivery.

### FOR YOUR CUSTOMERS TOO

One of the most immediate benefits of tracking data is in preventive maintenance. By collecting and analyzing data from your clients' plumbing systems, you can identify patterns and trends that indicate potential issues before they escalate into costly emergencies. Imagine being able to predict a pipe leak or a clogged drain before it happens, saving your clients time, money and headaches.

By leveraging technologies like Internet of Things sensors and smart meters, you can collect real-time data on water usage, pressure levels and temperature variations. This wealth of information opens up new opportunities for proactive maintenance, water conservation initiatives and even predictive analytics to anticipate future plumbing needs.

### GET BEHIND DATA

I urge you to embrace the power of data in your plumbing business. Whether you're a solo practitioner or a large-scale operation, tracking data can unlock a world of possibilities for efficiency, innovation and customer satisfaction.

Dive into the data pipeline and let it flow towards a brighter, more prosperous future for your business and the plumbing industry as a whole.

Let me know what data you collect and how you use it. You can email me at [editor@plumbermag.com](mailto:editor@plumbermag.com).

Enjoy this issue! 



PRO Series Full-Fixture Solutions  
**Discover the Duravit Difference**

Join the  
PRO network:



Partner with Duravit PRO Solutions for excellence in every build.  
Upgrade your projects with Duravit PRO Solutions.



# @plumbermag.com

Visit the site daily for new, exclusive content.

Read our blogs, find resources and get the most out of *Plumber Magazine*.



## CUSTOMER EDUCATION

### Tankless Water Heater Lessons

In the effort to recommend products to customers that can provide the best value and performance, one such product that has gained popularity over the years is the tankless water heater. In this online exclusive, regular contributor Anthony Pacilla provides some tips on upselling tankless water heaters to a customer who may be on the fence about switching over from a tank unit.

▲ [plumbermag.com/featured](http://plumbermag.com/featured)

## OVERHEARD ONLINE

*"Most companies have a ton of data but don't do anything useful with it. They, or the marketing company they work with, do a lot of analysis, yet they have no real understanding of what the data means."*

— *Learn How to Understand What Your Business' Data Metrics Are Telling You*

▲ [plumbermag.com/featured](http://plumbermag.com/featured)

## STAY SAFE

### Confined Space Ventilation Requirements

Forced air ventilation may be needed when occupying hazardous confined spaces on the job. As this online exclusive explains, you can calculate the required amount based on square footage and air exchanges per hour standards.

▲ [plumbermag.com/featured](http://plumbermag.com/featured)



## LEADERSHIP

### Be a Better Boss

This online exclusive cites the results of a study performed by Perceptyx, a company that specializes in employee surveys and people analytics: 24% of 1,500 employees polled said they currently work for the worst boss they've ever had. The key behavior that garnered either a worst- or best-boss ranking? Responsiveness. ▲ [plumbermag.com/featured](http://plumbermag.com/featured)



Join the Discussion

[Facebook.com/PlumberMag](https://www.facebook.com/PlumberMag)



[Twitter.com/PlumberMag](https://twitter.com/PlumberMag)

## NEWS & ALERTS



Visit [Plumbermag.com](http://Plumbermag.com) and sign up for newsletters and alerts. Get exclusive content delivered right to your inbox on topics important to you!

# ALLAN J. COLEMAN

SINCE 1905

**Call us today!**  
Chicago 773-728-2400  
Phoenix 602-638-0600

5725 N. Ravenswood Ave. • Chicago, IL 60660  
6003S 40th St., Ste. #5 • Phoenix, AZ 85042

info@allanjcoleman.com • www.allanjcoleman.com

**OLDEST NAME IN THE BUSINESS — Over 115 YEARS OLD**

**RIDGID**

## RP 241 Press Tool



- Multiple Size & System - RIDGID has the only compact press tool that can go up to 1 ¼" on copper & stainless steel; up to 1 ½" on PEX tubing; and up to ¾" iron pipe
- Bluetooth Connectivity - Connect to your tool through your phone and manage important information like cycle count and battery life
- New 12V Lithium-Ion Battery - Over 140 crimps per charge
- Jaw Capacities - copper and stainless steel capacity: ½" - 1 ¼", PEX Capacity: ½" - 1 ½", steel capacity: ½" - ¾"

## RP 351 Press Tool



- Brushless motor capable of over 100,000 press cycles
- Endless 360° head swivel for reaching tight spaces
- Bluetooth connectivity and advanced upgraded color-coded light indicators for easy operation
- Robust LED lighting for low-light applications
- Capacity - ½" to 4" for copper, carbon\* and stainless steel, ½" to 2" for PEX

\*Press Booster is needed for carbon steel

## Pipe Patch Kits

Pipe Patch Kits enable quick and efficient trenchless point repairs with all required consumables and components packaged together for one-time use. Patch Kits make inventory management easier on your business while ensuring you have all components needed when showing up to a job. Fiberglass patch meets ASTM F1216 requirements and cured patches have a life expectancy of up to 50 years under normal conditions. RIDGID Pipe Patch Kits are designed for 2", 3", 3-4", and 4-6" Packers and at lengths for 32", 3', and 6' repairs.

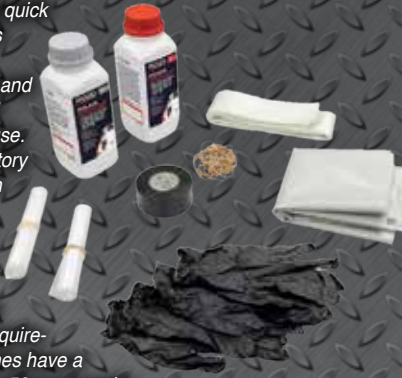

## MegaPress® Jaws And Rings

- Press connections can be made on a "wet" system
- Flameless system eliminates the need for hot work permits
- Join ½" to 2" commercially available black iron pipe schedules 5 through 40



**Authorized PROPRESS Service Center**

TURN AROUND TIME ON MOST TOOLS SERVICED IS 48 HOURS OR LESS!

**Now With 2 LOCATIONS  
To Better Serve You**



**Buy Online at  
AllanJColeman.com**

**If you buy the best,  
you are only sorry once!**

**We Have  
RIDGID Parts!**



◀ Nate Agentis, owner of Agentis Plumbing, at his company's shop in Bethlehem, Pennsylvania. Agentis is a third-generation owner of the company that his grandfather founded in 1954.

# Learning from **HISTORY**

Third-generation owner uses data-driven strategies to help shape a family business evolution

By Ken Wysocky | Photography by Hannah Beier



**Agentis Plumbing Inc., Bethlehem, Pennsylvania**

<b>OWNER</b>	Nate Agentis
<b>FOUNDED</b>	1954
<b>EMPLOYEES</b>	60
<b>SERVICES</b>	Residential and commercial service/repair plumbing, drain cleaning
<b>SERVICE AREA</b>	40-mile radius around Bethlehem
<b>WEBSITE</b>	<a href="http://agentisplumbing.com">agentisplumbing.com</a>

**I**

t's said that those who fail to learn from history are doomed to repeat it.

As the owner of Agentis Plumbing, Nate Agentis took that old adage to heart, which has helped him avoid the financial issues his father and grandfather faced and turn the third-generation family company in Bethlehem, Pennsylvania, into a growing and data-driven business.

"We swung the pendulum hard the other way," says Agentis, 43, who bought the business from his father in 2022. "I'm very serious about organizational structure and finances. We get financial updates every other day and I meet once a month with a financial consultant and an accountant.

"We also have proprietary customer-relations management software that provides a dashboard for every position, from dispatching to our warehouse to the technicians, who have iPads," he continues. "The dashboards tell us our leading and lagging metric and tell us when we beat or miss our goals.

"The bottom line is that numbers tell you the truth," Agentis adds. "Sometimes contractors feel like they're busy and making money, but they're not. Bringing in actual numbers and data shows us what's real and helps us fine-tune our decision-making process so we make

good decisions for the health of the company."

The company, which employs 60 people and runs about 50 service vehicles, was founded in 1954. Residential service and repair plumbing and drain cleaning generates about half of the company's income while commercial work contributes the balance, Agentis says.

## HUMBLE ORIGINS

Agentis' grandfather, George, started the business in 1954, after learning the plumbing trade during a stint in the United States Army. But like many tradesmen, he was good at his craft, but not a good businessman.

"My grandfather was soft-hearted and often worked for no fee," Agentis says. "He literally brought a horse home one day that he'd accepted as payment."

Agentis' father, Steve, took over the business in late 1977 when George Agentis ran into deep financial problems. Steve added drain cleaning to the company's services, which helped the company hit a financial milestone by 1994: \$1 million in revenue, Agentis says.

"My dad ran the business out of our home with help from my mom, Debbie," he recalls. "I grew up in the world of plumbing. I remember technicians playing Nintendo video games with me while they waited for service calls."



▶ Team leader Matthew Braciliano turns a valve on to restore water at a residential site after completing work.



▲ Plumber Dan Thomas removes a thermal expansion tank as the team works on replacing them with newer tanks.

Agentis worked for his grandfather and father at an early age, accompanying them on service calls and helping out in the shop.

“I was my dad’s little right-hand man, which was really fun,” Agentis says. “He was smart — he started me out at the bottom.”

## BUSINESS-LIKE APPROACH

After issues with delinquent taxes nearly forced the company to close its doors in 1977, Agentis’ father got serious about the business side of plumbing.

“He realized that in order to build a business, you have to run it smart, not just do the work,” Agentis says. “My mom got more involved, too.”

Along the way, his parents exposed Agentis more and more to things like bookkeeping and other business-related aspects of running a company. Agentis also went to college and earned a degree in management marketing. He graduated in 2002 — the same year he became a master plumber.

“My dad never forced me into plumbing — it just made sense,” Agentis says. “My grandpa did it and my dad did it and they made good money. So I wanted to be a part of it, too.”

In his mid-20s, Agentis transitioned from a service truck to a full-time office position, where he continued to learn about finances and dealt with customer complaints and so forth.

“I learned a lot about the business,” he says. “I got into strategic planning and business development as my dad scaled back and delegated more and more work to me.”

## Company Reaches Out to Help Those in Need

At Agentis Plumbing, a third-generation, family-owned company based in Bethlehem, Pennsylvania, “giving back” is a central tenet of the company’s culture.

Of course, a lot of companies say that. But owner Nate Agentis does more than pay lip service to the concept, as evidenced by a trip he took in May 2023 with eight technicians to build houses in Nicaragua. The mission was organized by a local church and the company donated \$10,000 to fund the construction of two houses.

“Giving back is part of my faith and who I am,” Agentis says. “It’s one of our core values, along with compassion, excellence, purpose and integrity.

“God has given us talents and the ability to make money and we want to use those for a bigger purpose than ourselves,” he adds. “There’s more purpose to life than getting a paycheck on Fridays.”

The trip also left a lasting impression on the technicians.

Agentis says some of his technicians have endured hard times during their lives, but standing on a smoldering landfill and watching people who live under tarps and pick through garbage to find scrap metal and food provided a valuable perspective.

“The people who live there do this every day,” he says. “I saw grown men crying while we stood on that landfill.

“Some of them told me it was one of the most life-changing things they’ve ever experienced,” Agentis continues. “That’s worth more than any money we can make back in the Lehigh Valley where we live.”

The company also partners with Samaritan’s Purse, an evangelical Christian organization that provides humanitarian aid both locally, nationally and abroad.

Agentis estimates the company spent about \$21,000 on the Nicaragua trip, including food, airline flights and lodging. And that doesn’t include the revenue lost by having eight technicians gone for a week, which equates to about a 10%



In 2011, Debbie was diagnosed with cancer and died about nine months later. After that, Agentis' father stopped doing plumbing work and opened a kitchen and bathroom store, leaving Agentis to run the company, which he eventually bought in 2022.

## BALANCED CUSTOMER BASE

Aside from the emphasis on collecting data and closely monitoring finances, Agentis cites several reasons for the company's growth, starting with developing a roughly 50/50 split between residential and commercial work.

"Doing both gives us a healthy business balance," he explains. "As long as your residential business is big enough, that's what supplies your cash flow. But given that an average homeowner calls a plumber only every five to seven years, you also need commercial work.

"You might get five calls a month from a commercial customer, plus you make more money on commercial jobs," Agentis adds. "But you also wait longer to get paid."

Agentis, who nurtures a faith-based company culture, says he loves doing residential work because it helps people in the surrounding communities.

"You feel like you're a part of people's lives and helping out families," he says.

Eliminating trip charges and emergency-service fees also plays a role in the company's success. While Agentis concedes it reduces revenue, he says it pays off by enhancing the company's reputation for honesty, plus it strongly differentiates the business from competitors.

"This past week, three customers said they called us

staffing decrease.

"It's a sacrifice as well as a commitment," he explains. "To handle the staffing shortage, we shift people around, don't schedule longer jobs and schedule as much emergency work as possible for the following week. We also left enough key people behind."

In 2024, Agentis plans to take another group of employees to Honduras. And once again, he expects the results will far outweigh any lost revenue.

"When you go to foreign country like Nicaragua, you see how few opportunities there are for people to pull themselves up by their bootstraps and better themselves," he says. "There basically aren't any jobs.



"So when we go into a community and build someone a home and give them the deed, it creates a new life for them — gives them a chance to break the cycle of poverty," Agentis adds. "It's truly amazing to see."



# WORKING WELL UNDER PRESSURE

PRICES GOOD THROUGH JULY 1ST OR WHILE QUANTITIES LAST

## Pressure Washers & Drain Jetting Equipment

<div style="text-align: center;">  <p><b>NEW</b></p> </div> <div style="border: 1px solid black; padding: 5px; text-align: center;"> <p><b>RCJ4008H</b></p> <p>»8.2 gpm @ 4000 psi    »200' x 3/8" Jet Hose              »800 cc EFI            on Manual Reel              Honda Engine  <b>30 GALLON TANK</b>    <b>\$8539 Plus Freight</b></p> </div>	<div style="text-align: center;">  <p><b>NEW</b></p> </div> <div style="border: 1px solid black; padding: 5px; text-align: center;"> <p><b>LJ4008H</b></p> <p>»8.2 gpm @ 4000 psi    »200' x 3/8" Jet Hose              »800 cc EFI            on Manual Reel              Honda Engine  <b>30 GALLON TANK</b>    <b>\$8399 Plus Freight</b></p> </div>	
<div style="text-align: center;">  <p><b>NEW</b></p> </div> <div style="border: 1px solid black; padding: 5px; text-align: center;"> <p><b>4008H POWER UNIT</b></p> <p>»8.2 gpm @ 4000 psi    »400' x 3/8" Jet Hose              »800 cc EFI            on DC Powered Reel              Honda Engine  <b>Just Add A Tank!</b>    <b>\$12,719 Plus Freight</b></p> </div>	<div style="border: 1px solid black; padding: 5px; text-align: center;"> <p><b>3012H POWER UNIT</b></p> <p>»12 gpm @ 3000 psi    »400' x 1/2" Jet Hose              »800 cc EFI            on DC Powered Reel              Honda Engine  <b>Just Add A Tank!</b>    <b>\$13,159 Plus Freight</b></p> </div>	
<div style="border: 1px solid black; padding: 5px; text-align: center;"> <p><b>3012H COMPACT SKID</b></p> <p>»12 gpm @ 3000 psi    »400' x 1/2" Jet Hose              »800 cc EFI            on DC Powered Reel              Honda Engine  <b>(100 GALLON TANK)</b>    <b>\$14,579 Plus Freight</b></p> </div>	<div style="text-align: center;">  <p><b>NEW</b></p> </div> <div style="border: 1px solid black; padding: 5px; text-align: center;"> <p><b>4008H COMPACT SKID</b></p> <p>»8.2 gpm @ 4000 psi    »400' x 3/8" Jet Hose              »800 cc EFI            on DC Powered Reel              Honda Engine  <b>(100 GALLON TANK)</b>    <b>\$14,129 Plus Freight</b></p> </div>	
<div style="text-align: center;">  </div> <div style="border: 1px solid black; padding: 5px; text-align: center;"> <p><b>VM4008H</b></p> <p>»8.2 gpm @ 4000 psi              »690 cc              Honda Engine              »50' x 3/8" Washdown Hose on DC Reel  <b>\$13,399 Plus Freight</b></p> </div>	<div style="text-align: center;">  </div> <div style="border: 1px solid black; padding: 5px; text-align: center;"> <p><b>STB3012H</b></p> <p>»12 gpm @ 3000 psi              »800 cc EFI              Honda Engine              »400' x 1/2" Jet Hose on DC Reel  <b>\$22,899 Plus Freight</b></p> </div>	<div style="text-align: center;">  </div> <div style="border: 1px solid black; padding: 5px; text-align: center;"> <p><b>STB4008H</b></p> <p>»8.2 gpm @ 4000 psi              »690 cc Honda Engine              »50' x 3/8" Washdown Hose on DC Reel  <b>\$22,299 Plus Freight</b></p> </div>

All Jets Shown Come with Pulse Valve, 2 Jet Nozzles, Tool Box, Gloves, Safety Glasses, Tip Cleaner, Tiger Tail, Wash Down Trigger Gun with Nozzles.

**Building Drain and Sewer Equipment since 1981.**

We Build Electric, Gas and Diesel powered models up to 4000 psi, flows up to 40 gallons per minute.  
 Don't see exactly what you want...  
 We will custom build exactly what you want!

**800-648-5011 | www.camspray.com | sales@camspray.com**



◀ Agentis Plumbing team leader Matthew Braciliano works at a residential site in Bethlehem, Pennsylvania, as he and his team work on replacing tanks on a water system at a property. Agentis Plumbing, owned by Nate Agentis, was founded in 1954 by Agentis' grandfather. The company now has 60 employees and works a 40-mile radius around Bethlehem.

for service because there was no trip fee," Agentis points out. "Other companies make people pay \$80 even though the customers probably don't know anything about the company.

"To me, it feels like entrapment because once you've paid that charge, you feel like you should use that company whether you want to or not," he continues. "By not charging those fees, we build trust with our customers. About 50% of our business is repeat customers."

## KEY INVESTMENTS

Investing in reliable and productivity-enhancing equipment also spurred growth. Today the company owns about 50 service vehicles, most of them either Ford Transits or GMC trucks equipped with box bodies made by Reading Truck.

For drain work, the company owns dozens of Electric Eel Model drain machines; a few Mini and Maxi Miller drain machines from Picote Solutions; and three trailer-mounted water jettors from Harben (a subsidiary of

Flowplant Group Ltd.), one Mongoose trailer jetter (a brand owned by Sewer Equipment) and two truck-mounted jettors, one equipped with a Harben unit and one with a Mongoose unit. The Mongoose machines feature UDOR water pumps.

The business also relies on RIDGID NaviTrak Scout pipe locators and dozens of pipeline-inspection cameras, mostly RIDGID SeeSnakes and units from Vivax-Metrotech.

In 2022, the company invested in a Bluelight pipelining system from HammerHead Trenchless.

## TRAINING AND POSITIVE CULTURE

Comprehensive technician training via an in-house program developed by Agentis also has been critical to success.

"This kind of training basically doesn't exist in the plumbing industry," Agentis says. "The training program includes detailed procedures for service tasks, including step-by-step procedures, material needed and so forth.

"We created our own videos for the program and technicians take a test after reading and watching the videos," he explains. "It helps us determine where technicians' strengths and weaknesses lie, which also helps us get the right technicians for the right jobs."

Aren't apprentice programs adequate? Not really, Agentis says, noting that apprenticeship training is largely building code-based and focuses primarily on new construction plumbing.

Continued ▶

“Sometimes contractors feel like they're busy and making money, but they're not. Bringing in actual numbers and data shows us what's real and helps us fine-tune our decision-making process so we make good decisions for the health of the company.”

Nick Agentis

# THE ADVANTAGE IS CLEAR



## INTRODUCING ClearLOC™

ClearLOC is an all-new see-thru push-to-connect fitting system from Legend. Its unique transparent body eliminates the need to measure and mark insertion depths. These fittings exceed ASSE 1061 pressure ratings by over 300%. ClearLOC is compatible with PE-RT, PEX, copper, and CPVC tube. Don't just take our word for it: seeing is believing.

 **LEGEND**® | AN EMPLOYEE-OWNED COMPANY

Learn More:



## Plumber Profile

- ▶ Team leader Matthew Braciliano, left, and plumber Dan Thomas, clean up at a job site after completing the work.
- ▼ The leadership team at Agentis Plumbing includes, from left, Paul Ward, project manager; Sam Housam, warehouse manager; Martin Gross, project manager; Conner Trinkle, project manager; and Nate Agentis, owner. The team poses for a photo near one of the company's box trucks.



“Apprenticeship programs are great, but if an apprentice rides with six different guys, he might learn how to set a toilet six different ways and possibly start taking shortcuts that create liability risks,” Agentis says.

Another key factor in the company's growth is its focus on building a faith-based, team-oriented culture. Agentis says that the company doesn't pay the highest wages in the area, but makes up for it with an emphasis on things such as retirement plans, career paths/promotions, teamwork, company-sponsored activities and regular encouragement and recognition, he says.

“Sometimes we lose people because they can get higher pay elsewhere, but we've also had five people come back,” he notes. “When it comes down to it, money is not the No. 1 priority for employees. I even have a handful of guys who took pay cuts to work here.”

### MORE GROWTH EXPECTED

Agentis says he has hired about 40 employees since he started running the company about 12 years ago, which reflects its steady growth. And he expects to keep growing, either through geographic market expansion or by acquiring other companies.

“But my ultimate objective is caring for my community and our employees and making enough money in the process to keep growing,” he says. “I want to make sure our people love to work here.”

Looking back, Agentis says he's “surprised, humbled and blessed” by the company's rapid growth. But he says it hasn't stemmed from his efforts alone.



“But my ultimate objective is caring for my community and our employees and making enough money in the process to keep growing,” he says. “I want to make sure our people love to work here.”

*Nick Agentis*

“God gave me a great team and everyone does their part to drive things forward,” he says. “It's all been a great gift.”

“This business was built on my dad's back,” he continues. “I walked into something that was well-established, which was another huge blessing for which I'm very grateful. Now it's my responsibility to keep building and growing it.”

### Featured Equipment

**Electric Eel Mfg.**  
800-833-1212  
[www.electriceel.com](http://www.electriceel.com)

**HammerHead Trenchless**  
800-331-6653  
[hammerheadtrenchless.com](http://hammerheadtrenchless.com)  
Ad on page 33

**Harben, Inc.**  
800-327-5387  
[www.harben.com](http://www.harben.com)

**Mongoose Jettors by Sewer Equipment**  
877-735-4640  
[www.sewerequipment.com/mongoose-jettors/](http://www.sewerequipment.com/mongoose-jettors/)  
Ad on page 39

**Picote Solutions**  
864-940-0088  
[www.picotegroup.com](http://www.picotegroup.com)  
Ad on page 69

**RIDGID**  
800-474-3443  
[www.ridgid.com](http://www.ridgid.com)

**UDOR U.S.A.**  
651-785-0666  
[www.udorusa.com](http://www.udorusa.com)

**Vivax-Metrotech Corp.**  
800-446-3392  
[www.vxmt.com](http://www.vxmt.com)  
Ad on page 53

YOUR TO-DO LIST CAN BE A LOT.  
WE MAKE ONE THING EASY.

SEE IF YOU  
CAN SAVE WITH  
PROGRESSIVE

Progressive Casualty Ins. Co. Coverage provided  
and serviced by affiliated and third-party insurers.



As a small business owner, you can't escape your to-do list.  
That's why Progressive makes it easy to save with a commercial  
auto quote, so you can take on all your other to-dos. Get a quote  
in as little as 7 minutes at [ProgressiveCommercial.com](http://ProgressiveCommercial.com)

**PROGRESSIVE**<sup>®</sup>  
COMMERCIAL

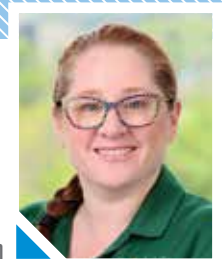

Katie Donovan

# Unlocking the Power of AI

A guide for home service businesses to navigate the emerging artificial intelligence age *By Katie Donovan*

**A**rtificial intelligence has emerged as the cornerstone of innovation within the home services industry, captivating professionals and consumers alike. Yet, amid the buzzwords and hype, the true essence of AI remains diverse and multifaceted, evoking varied interpretations and expectations.

According to *Bloomberg*, AI's impact is poised to affect nearly 40% of global job roles, underscoring its profound implications. Therefore, it's crucial to delve deeper into how AI will have consequential ripple effects through paid and organic search.

At a recent Google event, AI was heralded as “the third big shift,” following the advent of the internet a quarter-century ago and the subsequent mobile revolution. Each epoch has fundamentally altered our societal fabric and unprecedentedly disrupted industries. As AI looms on the horizon, it promises yet another paradigm shift in how we live and work.

Businesses and consumers alike are eager to harness the transformative potential of this technology. From its inception, the internet facilitated global connectivity and access to information, while mobile technology further personalized experiences, catering to immediate needs and desires in real time. Today, billions of searches are conducted daily on search engines, underscoring the pivotal role of AI in shaping our digital interactions.

As we navigate this new era of technological advancement, it's imperative to discern AI's true impact on home services and beyond. From enhancing efficiency to revolutionizing customer experiences, AI is the key to unlocking a future defined by seamless integration and unparalleled convenience.

## Unleashing AI's Potential in Marketing Strategy

As we delve deeper into the evolution of AI, its transformative potential within marketing becomes increasingly apparent. At the forefront of this revolution is “predictive AI,” which promises to revolutionize every facet of marketing strategy. Serving as the bedrock of data-driven decision-making, predictive AI discerns the who, where, when and how of marketing campaigns, leveraging insights from customer behaviors to achieve business objectives.

“Content Creation AI” epitomizes the widespread conception of AI, encompassing a myriad of creative endeavors from copywriting to image and video production. This versatile tool empowers marketers to craft personalized campaigns with unparalleled efficiency, seamlessly integrating customer names and preferences for a bespoke experience.

Machine learning, a cornerstone of AI technology, augments marketing efforts by identifying target demographics and optimizing ad placement in real-time. This AI-driven campaign optimization ensures maximum impact and conversion rates, propelling marketing strategies to new heights of effectiveness. It's important to note that machine learning AI has been around for quite some time and continues to improve.

In customer engagement, “Engagement AI” emerges as a game-changer, facilitating seamless interactions across various channels, from chatbots to voice assistants. This AI-driven interactivity extends beyond mere communication, offering invaluable insights into customer preferences and behavior to streamline operations and enhance service delivery.

The pervasiveness of AI extends far beyond marketing, permeating industries from navigation to social media management. From real-time updates on map applications to AI-powered social content generation, integrating AI technology enriches our daily experiences and empowers businesses to stay ahead of the curve.

As we embrace this new era of AI-driven innovation, combining human marketing expertise with cutting-edge

Embracing AI requires a willingness to test and scale new initiatives.

AI technology promises to revolutionize the industry landscape. By harnessing the power of AI, businesses can navigate the complexities of today's dynamic market with unparalleled agility and efficiency, ushering in a new era of transformative growth and innovation.

## Jump In! We're at an Inflection Point for Next-Level Growth

AI stands at a pivotal moment, akin to the transformative shifts experienced by television, which revolutionized planning, creativity and the production of iconic commercials. Subsequently, the internet ushered in an era of personalization and measurable advertising, driving monumental impacts for businesses of all scales. Mobile technology further elevated brand utility, assisting in every facet of our lives.

Many forward-thinking marketers, such as CAMP Digital, are already harnessing AI to unlock new opportunities. We've enthusiastically embraced this paradigm shift, recognizing that there's no better time to do so than now, given AI's proven efficacy. Recent tests at Google yielded staggering results for CAMP Digital, with a 70% increase in revenue and significant cost reductions for nearly one-third of the tests conducted.

Consequently, we've wholeheartedly integrated AI across our operations, leveraging its capabilities in search and combining it with Generative AI — empowering us to generate text, images, sounds, animations, 3D models and other data types. This holistic approach propels CAMP's customers toward next-level growth and profitability with a focus on enhancing customer connections, fostering creativity and bolstering our confidence in go-to-market strategies.

In today's dynamic marketplace, where customer journeys are increasingly intricate, and demand is swift, personalized responses, the fusion of AI-driven insights and innovative marketing solutions has become indispensable for businesses seeking to stay ahead of the curve. Some examples include:

### Customer Connections:

- AI enables marketers to uncover new pockets of demand in the rapidly evolving landscape of customer journeys, particularly in the home service trades.
- Today's purchase decisions are increasingly complex, dynamic and nuanced, with customers exhibiting behavior akin to "product detectives."
- For planned services, 61% of consumers utilize five or more online services before purchasing, engaging

# Pulsar 2000 Line Tracer

- ✓ Locate Lines
- ✓ Locate Water Leaks
- ✓ Training Video

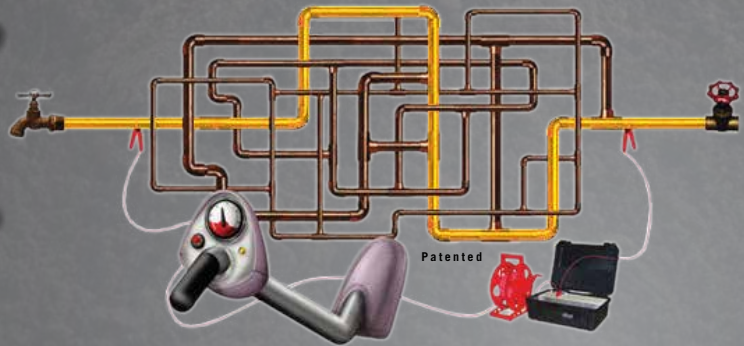

The **Pulsar 2000** line tracer is designed primarily to locate metallic pipes. The Pulsar 2000 is a directional line tracer. Connect the Pulsar's powerful and unique transmitter to your target pipe and locate only that pipe. Locating can be accomplished under floors, in walls and in ceilings. The Pulsar 2000 does not require grounding.

**Leak detection personnel...** The Pulsar 2000 is a must have locator. Now you can quickly identify the pipe location, thereby reducing the search area of the leak.

**100% satisfaction guarantee...** We are so sure that you will see the time saving benefit of the Pulsar 2000, we will let you return it for a full refund

if you are not satisfied. If you want to learn more about the Pulsar 2000 and our leak locating equipment, please call **214-388-8838** or e-mail [jsmll@aol.com](mailto:jsmll@aol.com) for a free demonstration video or CD and references of satisfied customers.

We have been using the **Pulsar 2000** along with the XL2 fluid detector and Geophones since January 1989 in our leak locating business. Our leak locates are **accurate 95% of the time**, but I can honestly say, the line we trace is always there. Our equipment is user-friendly and requires very little training, as you will see on the video. Purchase the **Pulsar 2000** line tracer, XL2 fluid detector and Geophones, and start locating leaks immediately.

*It's a jumble out there.*

**www.Pulsar2000.com**  
DISTRIBUTORS WANTED



in extensive research on reviews, financing, warranty, performance and cost.

- Demand services, such as emergency repairs, witness swift decision-making. Customers spend less than 20 minutes before taking action, highlighting the urgency and spontaneity of such transactions.
- Despite representing significant investments, HVAC system searches are often made hastily, emphasizing the need for marketers to deliver timely and relevant messages.

### AI-Powered Marketing Solutions:

- Implementing AI-powered campaigns like Google's Performance Max enhances search optimization across multiple channels, maximizing conversion opportunities and customer engagement.
- Enhanced conversion for web, an AI-powered solution, ensures accurate and privacy-safe measurement of marketing effectiveness, which is crucial in the era of impending cookie depreciation.

- Marketers leveraging enhanced conversions for the web witness significant improvements in conversion rates on search and YouTube, underscoring the efficacy of AI-driven strategies.
- AI-powered creative solutions offer endless possibilities for delivering tailored messages to customers, spanning various formats from short videos to display ads, ultimately driving higher return on investment.

### Experiment with 5-10% of Your Marketing Budget: Navigating the AI Frontier

In our forward-looking approach at CAMP Digital, we encourage businesses to allocate 5-10% of their marketing budget for experimentation and innovation in the coming year. While it may seem daunting, especially given rising costs and increasing competition for customer attention, reserving a dedicated portion for experimentation is the key to unlocking AI's potential.

Embracing AI requires a willingness to test and scale new initiatives. Despite the uncertainties, this investment in experimentation is the path to uncovering incremental conversion lifts. As we venture into uncharted territory, some experiments may lead to failures, but others can yield glorious successes, offering valuable insights and identifying opportunities for significant return on investment.

Staying agile is paramount. Ensure data, budgets and channels align seamlessly with marketing objectives and business goals. This agility, coupled with a keen focus on financial metrics, is crucial for adapting to the evolving landscape and harnessing the power of AI in marketing.

Remember, AI's true potential lies in its diverse applications across various industries. As the third shift in AI unfolds, businesses like ours in the trades can leverage its analytics, predictive, generative and creative capabilities. The horizon is wide open with possibilities, and in the upcoming months, we anticipate witnessing inspiring examples of brands utilizing AI in innovative ways. Let's stay abreast of these developments, adopting smart and forward-thinking strategies to propel our businesses into the future. 📱

*Katie Donovan is the co-founder and CEO of CAMP Digital, a leading digital marketing agency exclusively for companies in the home services industry. The award-winning agency leverages strategies in website design, SEO, paid ads and more for impactful campaigns to attract and convert quality leads while using its proprietary Capacity Pro dashboard that allows real-time adjustments to marketing strategy based on client capacity.*



**PIONEER OX  
WITH ATOMUS MD1  
CRUSHES**

SULFUR  
ORGANICS  
IRON  
MANGANESE  
& OTHER  
HEAVY METALS

ALSO FEATURING  
**PIONEER As  
WITH ATOMUS F11  
ARSENIC FILTRATION  
SOLUTION**

**NOW  
AVAILABLE!**

  
**ENPRESS LLC**  
Where Innovation Flows™

LEARN MORE  
  
ENPRESS.COM

**PIONEER™**  
**ATOMUS®** **GNE E3®** **Vortech**

ENPRESS®, ONE®, ATOMUS®, VORTECH®, AND E3® are trademarks of ENPRESS, LLC. US and International patents, and patent pending.  
© ENPRESS LLC 2023 | ONE® is an ENPRESS Filtration Technology



**CRANE**

PUMPS & SYSTEMS

# BARNES<sup>®</sup>

*Leader in Wastewater Innovation*



## **Pumps For All Your Plumbing Needs**

Our comprehensive range of sewage ejectors, effluent, and sump pumps set the standard in innovation and reliability. Whatever your challenge, our advanced technologies deliver unparalleled performance for every application.

[CRANEPUMPS.COM](http://CRANEPUMPS.COM)





Kate Zabriskie

# Unraveling Complexity

Simpler approaches to serving customers will improve their experience, encourage them to call again and again

By Kate Zabriskie

*“Who designed this convoluted process? A monkey could have done a better job.”*

*“Why do I have to come in and talk to someone? This whole transaction could be handled online. Frustrating!”*

*“I dread going there. The parking lot is impossible to navigate, you fill out what seems like 8,000 forms before you see anyone, and often the staff is confused by the complexity of the processes they follow. I’m glad I only have to go there once or twice a year.”*

Every day, countless service providers make choices that unnecessarily complicate service interactions. At best, those decisions make the customer experience less enjoyable. At worst, unneeded complexity opens the door to complaints, bad reviews and competitors.

## GOOD & SIMPLE

Organizations that know the value of simplicity strive to streamline processes and eliminate rocks on the service-experience road. Furthermore, those who understand the importance of effortless service know achieving it is an ongoing group effort. From the boardroom to the service window, everyone from top to bottom diligently works to eradicate needless steps, complexities or jargon that may confuse customers and obstruct them from reaching their goals.

### Examples of the Payoffs

**Streamlined processes:** Simplifying processes, procedures and workflows eliminates unnecessary complexities, making customer interactions more efficient and effortless.

**Clear communication:** Using straightforward language ensures product information, instructions and policies are easily understandable, creating a faster customer experience.

**Intuitive navigation:** Creating intuitive interfaces helps customers quickly find what they need without clicking on the wrong link, going to the incorrect location or calling the wrong number.

**Reduced cognitive load:** Organizing information and choices in a clear and logical manner helps customers make

confident decisions, reducing the likelihood of buyer’s remorse, returns or calls to the help desk.

**Efficient problem resolution:** Providing simple and accessible channels for customer support enables quicker problem resolution.

**User engagement:** Presenting information or products in a simplified way makes customers want to use a service provider.

## WE’RE DIFFERENT

My business is complicated! We’re not running a hamburger stand or a retail store. Our product is highly technical. While not every interaction is basic, all service providers can make interactions easier. No matter who you are, there are opportunities to streamline design, usability, communication, accessibility and problem resolution.

**Obvious opportunities:** If you open your eyes, many problems are obvious. Here are a few of the usual suspects: complex payment process, inefficient customer relationship management systems, excessive use of industry jargon, multiple contact attempts.

**Other places to explore:** In addition to the easy-to-find improvement opportunities, most teams can find more if they start asking questions:

1. Is our product or service easy to understand?
2. Is our website or physical location easy to navigate?
3. Can customers easily find the information they need?
4. Are our pricing and billing practices transparent and easy to understand?
5. Can customers quickly contact us when they need to?
6. Is our customer service process straightforward and efficient?
7. Are we using plain language in our communications or relying too much on jargon?
8. Are our processes designed with the customer’s convenience in mind?
9. Are we offering simple, efficient solutions to customer problems?

10. Can customers easily purchase our products or services?

11. Do customers have to go through unnecessary steps or complexities to achieve their objectives?

12. What feedback are we getting from customers about the ease of their experience?

The front line is a gold mine: Organizations that take simplicity seriously know the goldmine of information frontline service representatives can provide if they are encouraged to bring issues to management.

Routine complaints: For every customer who voices dissatisfaction, three or four others will say nothing. Organizations that treat service seriously see complaints as canaries in the coal mine, and they encourage service representatives to track concerns and bring them forward.

Multiple contact attempts: If customers need to contact your company multiple times for the same issue or related issues, there's a problem and an opportunity to simplify the resolution process. Frontline representatives are almost always the first to recognize boomerang interactions.

Poorly defined policies: Confused and confounded customers are the result of poorly defined policies. Representatives who must manage them know when guidelines or rules are ill-defined.

Lack of training and tools: Frontline service providers

Organizations that know the value of simplicity strive to streamline processes and eliminate rocks on the service-experience road.

are also acutely aware when they don't know the answer, can't get a system to cooperate or must implement a workaround.

### KEEP IT SIMPLE

Once you start looking, it's easy to become overwhelmed by the amount of work involved to make things easy. Take a breath, and then take another. Just as most processes don't become convoluted overnight, it takes time to go in the other direction.

Start with straightforward fixes to build momentum. Next, prioritize what is easier to implement and what will have the most impact on the customer experience. Then get to work. 

-----  
*Kate Zabriskie is president of Business Training Works Inc., a Maryland-based talent development firm. Reach her at [www.businesstrainingworks.com](http://www.businesstrainingworks.com).*



**WHERE SPACE MEETS EFFICIENCY!**  
Providing Innovative Narrow Wall Solutions



**P-628**  
**HOT & COLD**



**Fits in 2x4 Wall**

**8 GPM at 25 PSI**

**4 Orientation Options**

**Integral Shutoffs for Easy Maintenance**

**P-623**  
Single-Temp



Scan to EXPLORE



**WWW.PRIER.COM 800-362-9055 ORDERS@PRIER.COM**



Ken Dickerson

# What It Takes to be a Plumber

As workforce gets older, there needs to be a call for proper training and mentorship in the trade

By Ken Dickerson

If you have a passion for plumbing like I do, you most likely read as much as you can about the subject. The variety of what I read can range from new products to plumbers' opinions on certain topics. I enjoy it all.

As I was reading an article from a colleague who teaches plumbing apprenticeship at a different college, he wrote about his favorite code citation, which really put me back in my seat to think. What is my favorite code citation? For each person, this can be on the total opposite sides of our code book, and whatever your favorite code citation is, that is the right one for you.

Personally, mine is SPS 382.015. That code citation reads "the purpose of this chapter is to provide that all plumbing in connections with buildings and facilities in the state, including buildings owned by the state or any political subdivision thereof, shall be safe, sanitary and such as to safeguard the public health and the waters of the state."

What a bold statement to put on us plumbers. Essentially, we have to make sure that no person gets sick from our installs and that we don't contaminate any water throughout our state. A mentor of mine once said that plumbing was the most noble profession in the world, and after reading that, I think he may be right!

This goes for all plumbers regardless of what you may actually do in your everyday job. From preventing cross connections, to requiring an indirect waste connection, to water distribution materials, to discharging wastewater effluent back into the earth via a private onsite wastewater treatment system, I could go on and on.

## PROPER TRAINING NEEDED

In order for us to even attempt to follow any of our code citations we need the proper training. Most states either require an apprenticeship or work experience under the direct supervision of a licensed plumber.

The training both inside the classroom and out in their daily duties are so valuable to the plumbing profession.

The training, both inside the classroom and out in their daily duties, is so valuable to the plumbing profession. This is no simple task and will take years for the very beginner to become even a novice in the plumbing world.

I found this in an article published in an issue of *Domestic Engineering* from 1919. It's about an apprenticeship plan, arguing that the necessity for more care in the selection of plumbing apprentices is plain to every tradesperson in the craft. If a low grade of apprenticeship has been the rule in the past, it has been due to improper selection of apprentices and lack of sympathetic direction and cooperation on the part of the master and journeyman. An untrained or half-trained apprentice, or one whose inclinations are in other directions, lowers the standard of plumbers and plumbing.

Reading the paragraph from 1919 makes me wonder about a couple of things. Do most plumbing shops have an apprenticeship plan? What do they expect from an apprentice and what can an apprentice expect from them? Both the apprentice and the journeyman should help one another. For example, here in Wisconsin we just passed a code update, our first since 2008, and the very first people to see and understand the updates are the apprentices. Their job is to inform the entire shop and keep them up to date with these code updates. This can be difficult if there is not a plan or proper expectations of one another.

Why aren't we selecting our future plumbers with more care? Why are we not giving them the proper training that they need and deserve? Is it all about the numbers? According

to the Bureau of Labor Statistics, plumbing will grow about 2% by 2032 and with approximately half our workforce being 50-plus years old. That means we have to train more people in the next 10 years than we have had to over the last several decades combined! Now I certainly don't advocate for less training in the plumbing trade, but I think that it would be nearly impossible to still protect the public health and the waters of the state. How are we expecting the very best from our apprentices if we don't give them the ample direct supervision they need and deserve?

### A CHANGE NEEDED?

We know finding good quality help that you can train and mold into the plumber that works best for your company was just as hard to find 100 years ago as it is now! How can this still be happening 100 years later? Maybe we need to make a change on how we look at training?

I know that we may have run into the journeyman in our career that belittles every aspect of our professional life and makes plumbing very difficult. This may be from the old adage of the younger plumber making less money and having more energy to complete more tasks during the workday, so let's make their life harder to build up my own worth. I think that mentality is just nonsense. I have always

had the mindset to train as many people as I can to make my job that much easier. Now I know that as I grow older in years my ability to do certain installs may diminish, my knowledge and ability to train grows exponentially, making my worth to the company even more valuable, not less.

I see way too many beginner plumbers sent out on their own doing the oddest of stuff because of lack of training. As an apprenticeship teacher, I have approximately 90 different students over a two-week period describe what they are seeing and doing in the field. This ranges from service, to remodels, to new construction, to POWTS. Now sometimes I do think they have some great ideas that I would have never thought about doing. However, most of the time the install is either not code-compliant, not fixed efficiently, or both. I don't want to say that I've heard it all, but hearing the perspective from 90 different apprentices a year allows me to hear a plethora of unique installs.

The future comes at you fast. It starts today, and it starts with you. **P**

-----  
*Ken Dickerson teaches plumbing apprenticeship at Waukesha County Technical College. He is the 2022 Associated Builders and Contractors of Wisconsin Instructor of the Year, a U.S. Air Force veteran and proud husband and father of two. To reach Ken, email [editor@plumbermag.com](mailto:editor@plumbermag.com).*

**AQUAREX®**  
**IS THE BEST "NO SALT SOFTENER"**

**The Test report from IAPMO R & T Labs tells you that**

**Watch this video to understand Aqua-Rex**

**Only available to Professional Service Plumbers**  
**Own Branded options available**  
**Set your own pricing - No MAP**  
**Don't bother looking for it on online - it is not there.**  
**No web sales allowed**

**Stake a claim for your exclusive territory contact us NOW!**

Tel: 877 640 2170 | email: [info@aqua-rex.com](mailto:info@aqua-rex.com) | [www.aqua-rex.com](http://www.aqua-rex.com)



# Plumber<sup>®</sup> 2024 ANNUAL BUYER'S GUIDE

## ALPHABETICAL LISTINGS

Companies who advertise in this publication have their company name listed in bold and in color. Please be sure to view their ad on the listed page within this magazine.

### A

**A.Y. McDonald Mfg. Co.**  
PO Box 508  
Dubuque, IA 52004  
800-292-2737 • 563-583-7311  
sales@aymcdonald.com  
www.aymcdonald.com

### **ACME<sup>®</sup>** **TRENCHLESS**

**ACME Trenchless**  
W13355 Co Rd. KK  
Ripon, WI 54971  
920-376-4222  
sales@acmetrenchless.com  
www.acmetrenchless.com  
**Ad on page 67**

**Allan J. Coleman Co.**  
5725 N Ravenswood Ave.  
Chicago, IL 60660  
773-728-2400  
info@allancoleman.com  
www.allancoleman.com  
**Ad on page 11**

**Alpine Equipment Funding, Inc.**  
120 Newport Center Dr., Ste. 100  
Newport Beach, CA 92660  
800-640-8660  
clayton@alpinefunding.us  
www.alpineequipmentfunding.com

### **American Jetter**

6908 Pine Grove Rd.  
Knoxville, TN 37914  
866-944-3569 • 865-524-4647 • Fax: 865-247-5105  
office@americanpridedist.com  
www.americanjetter.com  
**Ad on page 73**

### **American Pipelining Supplies**

233 Camson Rd.  
Anderson, SC 29625  
888-258-9359  
sales@pipeliningsuppliesusa.com  
www.americanpipeliningsupplies.com

### **Aqua-Rex LLC**

3301 Spring Mountain Rd., Ste. 18  
Las Vegas, NV 89102  
877-640-2170 • 702-304-2170  
info@aqua-rex.com  
www.aqua-rex.com  
**Ad on page 27**

### **AQUAGUARD LLC**

780 Wellington Ave.  
Cranston, RI 02910  
844-438-9247  
sales@wagsvalve.com  
www.wagsvalve.com  
**Ad on page 51**

## AquaMotion, Inc.

88 C Jefferson Blvd.  
Warwick, RI 02888  
401-785-3000 • Fax: 401-785-3033  
info@AquaMotionHVAC.com  
www.aquamotionhvac.com

## Arcan Enterprises

PO Box 31057  
Clarksville, TN 37040  
888-352-7226 • Fax: 931-368-1904  
arcan@charter.net  
www.arcan.com

**Ad on page 73**

## Arctic Blaster, Inc.

Site 122 Comp 72 RR3  
Sundre, AB TOM 1X0  
403-636-1488  
bruno@arcticblaster2023.com  
www.arcticblaster.com



## Arrowhead Brass

5147 Alhambra Ave.  
Los Angeles, CA 90032  
800-332-4267  
customer.service@arrowheadbrass.com  
www.arrowheadbrass.com

## Arthur Products Co.

1140 Industrial Pkwy.  
Medina, OH 44256  
800-322-0510 • 330-725-4905 • Fax: 330-722-2698  
apc@apclsa.com  
www.arthurproducts.com

## Asahi/America, Inc.

655 Andover St.  
Lawrence, MA 01843  
800-343-3618 • 781-321-5409 • Fax: 800-787-6861  
asahi@asahi-america.com  
www.asahi-america.com

## Ashland Pump

1899 Cottage St.  
Ashland, OH 44805  
855-281-6830  
customerservice@ashlandwatergroup.com  
www.ashlandpump.com

**Ad on page 53**

## B

### Blackhawk Tech

910 W Wilson St.  
Batavia, IL 60510  
630-326-9061  
info@blackhawktechsupply.com  
www.blackhawktechsupply.com



725 Talamore Dr.  
Ambler, PA 19002-1873  
215-641-9400  
www.bradfordwhite.com

**Ad on page 47**

## C

### Cam Spray

520 Brooks Rd.  
Iowa Falls, IA 50126  
800-648-5011 • 641-648-5011  
sales@camspray.com  
www.camspray.com  
**Ad on page 15**

### Central Oklahoma Winnelson

5037 NW 10th St.  
Oklahoma City, OK 73127  
888-947-8761 • 405-947-8761 • Fax: 405-947-1934  
krjones@winnelson.com  
www.centralwinnelson.com

**Ad on page 49**



### Cherne Industries

2300 Vierling Dr. W  
Shakopee, MN 55379  
800-843-7584  
www.cherneind.com

### Corro-Protec

40 Boulevard Industriel  
Princeville, QC G6L 4P2  
877-466-6660  
info@corroprotec.com  
www.corroprotec.com/  
product/water-heater-anode-rod

## CPI Products

CPI Products / Cavallero Plastics  
1250 North St.  
Pittsfield, MA 01201  
413-443-0925 • Fax: 413-443-9586  
www.cplproducts.com

## Crane Pumps & Systems

420 Third St.  
Piqua, OH 45356  
937-773-2442  
cranepumps@cranepumps.com  
www.cranepumps.com

**Ad on page 23**

## Cua Claws for Resurfacing Camera Wheels

2376 Maize Rd.  
Twenty-nine Palms, CA 92277-9736  
714-697-8697  
jerry@cuaclaws.com  
www.cuaclaws.com

**Ad on page 73**



### CUES, Inc.

3600 Rio Vista Ave.  
Orlando, FL 32805  
800-327-7791 • Fax: 407-425-1569  
salesinfo@cuesinc.com  
www.cuesinc.com

## D



### Dallas Specialty & Mfg. Co.

1161 Ruggles St.  
Grand Prairie, TX 75050  
800-222-5644 • 972-641-8444 • Fax: 972-641-8488  
ds@dalspc.com  
www.dallaspecialty.com  
**Ad on page 51**

### Duracable Manufacturing Co.

300 Ashworth Rd.  
West Des Moines, IA 50265  
800-247-4081  
sales@duracable.com  
www.duracable.com

**Ad on page 43**

### Duravit USA, Inc.

2635 N Berkeley Lake Rd., Ste. 100  
Duluth, GA 30096  
770-931-3575 • Fax: 770-931-8454  
info@us.duravit.com  
www.pro.duravit.us/  
**Ad on page 9**

### Dyna Flex, Inc.

1000 Bacon Rd.  
Painsville, OH 44077  
440-946-9424  
sales@flexinc.com  
www.dynaflexinc.com

## E

### Easy-Kleen Pressure Systems Ltd.

41 Earnhardt Rd.  
Sussex Corner, NB E4E 6A1  
800-315-5533 • 506-433-3393 • Fax: 506-433-2443  
sales@easykleen.com  
www.easykleen.com

Ad on page 67

### EasyCAM

6230 Shirley St., Ste. 105  
Naples, FL 34109  
239-260-2056  
Easycamrick@gmail.com  
www.easycamlc.com

## THE SHOOTER®

### EMAGINEERED SOLUTIONS INC

1830 SE 1st St.  
Redmond, OR 97756  
541-504-0416  
ray.i@emagineered.com  
www.theshooteripp.com



### ENPRESS LLC

34899 Curtis Blvd.  
Eastlake, OH 44095  
866-859-9274 • 440-510-0108 • Fax: 440-510-0202  
info@enpress.com  
www.enpress.com

Ad on page 22

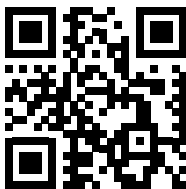

### EPL Solutions, Inc.

1330 W Collins Ave.  
Orange, CA 92867  
714-453-9769  
sales@epls-usa.com  
www.epls-usa.com

## F

### FastEST, Inc.

2420 N Woodlawn Blvd., Bldg. 100A  
Wichita, KS 67220  
800-828-7108 • Fax: 316-618-1064  
Fastest@fastest-inc.com  
www.fastest-inc.com

Ad on page 69

### FORMADRAIN

10121 Parkway Blvd.  
Montreal, QC H1J 1P7  
888-337-6764 • 514-352-6911  
carl@formadrain.com  
https://formadrain.com/

Ad on page 31

## G

## General PIPE CLEANERS

### General Pipe Cleaners, div. of General Wire Spring

1101 Thompson Ave.  
McKees Rocks, PA 15136  
800-245-6200 • 412-771-6300  
info@drainbrain.com  
www.drainbrain.com

Ad on page 76

### General Pump

1174 Northland Dr.  
Mendota Heights, MN 55120  
888-474-5487 • 651-454-6500 • Fax: 651-454-8015  
sales@gpccompanies.com  
www.generalpump.com

### Gorlitz Sewer & Drain, Inc.

10132 Norwalk Blvd.  
Santa Fe Springs, CA 90670  
877-446-7548 • 562-944-3060 • Fax: 562-944-7630  
sales@gorlitz.com  
www.gorlitz.com

## H

### Hammelmann

436 Southpointe Dr.  
Dayton, OH 45342  
800-783-4935 • 937-859-8777  
mail@hammelmann.com  
www.hammelmann.com

### HammerHead Trenchless

500 South C.P. Ave.  
Lake Mills, WI 53551  
800-331-6653 • 920-648-4848 • Fax: 920-648-1781  
info@hammerheadtrenchless.com  
www.hammerheadtrenchless.com

Ad on page 33

### Heat-flo

15 Megan Ct.  
Uxbridge, MA 01569  
508-278-2400 • Fax: 508-278-2466  
www.heat-flo.com

Ad on page 57



### Hermann Sewerin GmbH

Robert-Bosch-Strasse, 3  
D-33334 Gutersloh  
Germany  
888-592-9916  
sewerin-usa@sewerin.net  
www.sewerin.net

Ad on page 49

### HotJet USA

14773 Heritage Crest Way  
Riverton, UT 84065  
800-624-8186 • 801-545-0777  
sales@hotjetusa.com  
www.hotjetusa.com

Ad on page 3, 73



### Hydra-Flex, Inc.

8401 Eagle Creek Pkwy.  
Savage, MN 55378  
952-808-3640  
hello@hydraflexinc.com  
www.hydraflexinc.com



### Infrastructure Repair Systems, Inc.

4301 34th St. N, Ste. A  
St. Petersburg, FL 33714  
727-327-4216 • Fax: 727-327-4118  
irsi@irsi.net  
www.irsi.net

### Insight Vision Cameras

600 N Dekora Woods Blvd.  
Saukville, WI 53080  
800-488-8177 • 262-268-9330  
sales@gainsightvision.com  
www.gainsightvision.com

### IntelliHot Inc.

750 Bunker Ct.  
Vernon Hills, IL 60061  
866-692-6791 • Fax: 877-835-1705  
info@intellihot.com  
www.intellihot.com

### IPP Solutions, LLC

PO Box 4160  
Gypsum, CO 81637  
970-444-5655  
info@ippsolutions.com  
www.ippsolutions.com

Ad on page 59

## J

### J.M. McKinney Co.

12710 Yukon Ave.  
Hawthorne, CA 90250  
800-821-7275 • 310-978-9650 • Fax: 310-978-2795  
jmco4u@hotmail.com

### JETERS NORTHWEST

16750 Redmond-Woodinville Rd. NE, Ste. C-101  
Woodinville, WA 98071  
877-901-1936 • 206-283-5252  
info@jetersnorthwest.com  
www.jetersnorthwest.com



# Industrial-strength CIPP resin for extreme conditions

Tackle your toughest industrial plumbing challenges with Formapox 301.



**Formapox 301 is not just another liner; it's your insurance against the most demanding industrial conditions. Cover pipe sizes from 2" (50 mm) to 48" (1200 mm) and lengths from 1' (0.3 m) to 100' (30 m).**

**You need a liner as tough as your hardest day on the job: Formapox 301.**

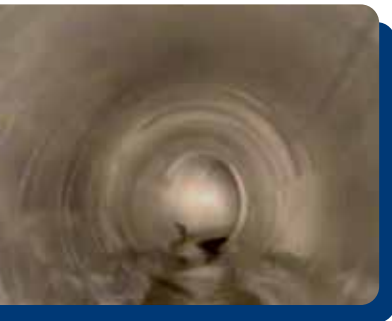

## ENGINEERED FOR THE EXTREME

- Corrosive acids (e.g., sulphuric acid)
- Strong bases (e.g., caustics)
- Powerful solvents (e.g., in petroleum applications)
- High temperatures (up to 250°F/120°C)



## WHY FORMAPOX 301?

- 100% no-dig solution
- Fast, high-quality steam-cured and watertight repairs
- Perfect for transitions and offset joints
- Safe for underground utilities
- Free from VOCs

**Act now!**

**Don't let harsh environments dictate your project's success. Choose Formapox 301 for unmatched durability and performance.**

formadrain.com | 1-888-337-6764



## L



Manufactured by Vanderlans & Sons, Inc.

**Lansas Mfg. by Vanderlans & Sons Inc.**

1320 S Sacramento St.

Lodi, CA 95240

800-452-4902 • 209-334-4115 • Fax: 209-339-8260

info@lansas.com

www.lansas.com

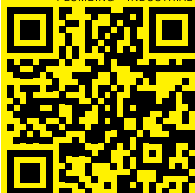

**Legend Valve**

300 N Opdyke Rd.

Auburn Hills, MI 48326

800-752-2082 • 248-630-7400 • Fax: 800-835-4457

service@legendvalve.com

www.legendvalve.com

Ad on page 17

**Liberty Pumps**

7000 Apple Tree Ave.

Bergen, NY 14416

800-543-2550 • 585-494-1817

Liberty@LibertyPumps.com

www.LibertyPumps.com

Ad on page 41

**Little Giant**

9255 Coverdale Rd.

Fort Wayne, IN 46809

800-701-7894 • 260-824-2900

CustomerSupport@fele.com

www.LittleGiant.com

Ad on page 35

## M



**MaxLiner**

901 Hollie Dr.

Martinsville, VA 24112

877-426-5948 • Fax: 276-656-0419

info@maxlinerusa.com

www.maxlinerusa.com

Ad on page 75

**Milwaukee Rubber Products, Inc.**

N52 W13319 Falls Creek Ct.

Menomonee Falls, WI 53051

800-325-3730 • 262-781-7888 • Fax: 262-781-1742

sales@milwaukeeerubber.com

www.milwaukeeerubber.com



**Mongoose Jettors by Sewer Equipment**

1590 Dutch Rd.

Dixon, IL 61021

877-735-4640

sales@mongoosejettors.com

www.sewerequipment.com/mongoose-jettors/

Ad on page 39

**MyTana LLC**

746 Selby Ave.

St. Paul, MN 55104

866-735-7684 • 651-222-1738

mytana@idexcorp.com

www.mytana.com

Ad on page 61

## N

**Noritz America**

11160 Grace Ave.

Fountain Valley, CA 92708

714-422-8120

www.noritz.com

**Norweco, Inc.**

220 Republic St.

Norwalk, OH 44857

800-667-9326 • 419-668-4471 • Fax: 419-663-5440

email@norweco.com

www.norweco.com

**NuFlow Technologies**

1270 W Mission Ave.

Escondido, CA 92029

866-430-2134

info@nuflow.com

www.nuflow.com

Ad on page 37

## O

**Oatey Co.**

20600 Emerald Pkwy.

Cleveland, OH 44135

800-321-9532

www.oatey.com

Ad on page 45

## P

**Pearpoint Inc.**

39-740 Garand Ln., Unit B

Palm Desert, CA 92211

800-688-8094 • 760-343-7350 • Fax: 760-343-7351

pearpoint.sales.us@spx.com

www.pearpoint.com



**Picote Solutions**

777 W Pinnacle Peak Rd., Ste. B-108

Phoenix, AZ 85027

864-940-0088

sales@picotesolutions.com

www.picotegroup.com

Ad on page 69

**Pipeline Renewal Technologies**

111 Canfield Ave., Unit C

Randolph, NJ 07869

866-936-8476

pipeline@idexcorp.com

www.pipeline.com

Ad on page 65

**Pow-r Mole Trenchless Solutions**

1400 Commerce Pkwy.

Lancaster, NY 14086

800-344-6653 • 716-683-2486

www.powmole.com

**Precision Plumbing Products**

802 SW 199th Ave

Portland, OR 97233

503-256-4010 • Fax: 503-256-8165

sales@ppcinc.net

www.ppcinc.net

**PRIER Products**

4515 E 139th St.

Grandview, MO 64030

800-362-9055 • Fax: 800-362-1463

orders@prier.com

www.prier.com

Ad on page 25

**Progressive Insurance**

300 N Commons Blvd.

Mayfield Village, OH 44143

800-776-4737 • 440-461-5000

www.progressivecommercial.com

Ad on page 19

**Pulsar 2000, Inc.**

2405 IH 30

Mesquite, TX 75150

214-388-8838

jsmll@aol.com

www.pulsar2000.com

Ad on page 21

## Q

**Qescorp d/b/a DiscountSawBlade.com**

PO Box 851232

Richardson, TX 75085-1232

888-641-9798 • Fax: 214-363-2451

www.discountssawblade.com

Ad on page 71

**HAMMERHEAD®**  
TRENCHLESS

**OUR SYSTEMS YOUR SOLUTION**



**WHEN IT COMES TO REHABILITATING AGING AND DETERIORATING PIPES, WE'VE GOT YOU COVERED.**

Our industry leading lateral rehab system drowns out the competition. We test all our products in the field and when paired together they are elite in every standard. We're here to help you do more, in less time, with less interference. When you choose HammerHead you're choosing **integrated solutions, with superior results.**

Dominate your projects at: [hammerheadtrenchless.com](http://hammerheadtrenchless.com)

## R

### Ratech Electronics, Ltd.

260 Spinnaker Way, Ste. 7  
Vaughan, ON L4K 4P9  
800-461-9200 • 905-660-7072 • Fax: 905-660-1519  
sales@ratech-electronics.com  
www.ratech-electronics.com

### rauschUSA

#### RauschUSA

1686 Opportunity Ave.  
Chambersburg, PA 17201  
877-728-7241 • 717-709-1005 • Fax: 717-709-1009  
sales@rauschusa.com  
www.rauschusa.com  
**Ad on page 55**



### REHAU Construction

1501 Edwards Ferry Rd. NE  
Leesburg, VA 20176  
800-247-9445 • 703-777-5255  
rehau.mailbox@rehau.com  
www.na.rehau.com

### Roddie Inc

4457 Trumble Creek Rd.  
Columbia Falls, MT 59912  
888-406-3821 • 406-730-1565 • Fax: 888-406-8282  
sales@roddieunderground.com  
www.roddieunderground.com  
**Ad on page 5**



### RootX

PO Box 7626  
Salem, OR 97303  
800-844-4974 • 503-364-2999  
rootx@rootx.com  
www.rootx.com

### Root Rat

PO Box 196  
Bolivar, OH 44612  
800-288-7873 • 330-874-4300 • Fax: 330-874-4448  
kelly@chempure.com  
www.rootrat.net  
**Ad on page 73**

## S

### SalesMaker Carts

418 Roberts Ave  
Louisville, KY 40214  
800-821-4140  
www.salesmakercarts.com  
**Ad on page 65**

### Saniflo SFA Inc.

105 Newfield Ave., Ste. B  
Edison, NJ 08837  
800-571-8191 • Fax: 732-225-6072  
sfasales@saniflo.com  
www.saniflo.com



### Shamrock Nozzles By Triton HydroTools

11210 S Choctaw Dr.  
Baton Rouge, LA 70815  
800-633-7696 • 225-275-7696  
sales@tritonhydrotools.com  
www.shamrocktools.com

### SJE Rhombus

22650 Cty. Hwy. 6  
Detroit Lakes, MN 56501  
888-342-5753 • 218-847-1317 • Fax: 218-847-4617  
sje@sjeinc.com  
www.sjerhombus.com

### Source ONE Environmental

300 S Dayton St.  
Davison, MI 48423  
877-450-3701 • 810-412-4740  
service@s1eonline.com  
www.s1eonline.com



### SPARTAN TOOL

#### Spartan Tool LLC

1618 Terminal Rd.  
Niles, MI 49120  
800-435-3866  
customerservice@spartantool.com  
www.spartantool.com  
**Ad on page 2**

### SpitzLift Manufacturing

PO Box 30  
Cowden, AL 36523  
619-713-5061  
info@spitzlift.com  
www.spitzlift.com



### Superior Signal Company LLC

178 W Greystone Rd.  
Old Bridge, NJ 08857  
732-251-0800 • Fax: 732-251-9442  
info@superiorsignal.com  
www.SuperiorSignal.com/PLBG  
**Ad on page 73**

### SuppliesDepot.com

667 S Delsea Dr.  
Vineland, NJ 08360  
800-359-1334  
sales@suppliesdepot.com  
www.suppliesdepot.com  
**Ad on page 7**

### Suttner America Company

14864 W Ridge Ln.  
Dubuque, IA 52003  
800-831-0660 • 563-556-3212 • Fax: 800-821-0660  
sales@suttner.com  
www.suttner.com

## T



### TRIC Tools, Inc.

415 Pendleton Way  
Oakland, CA 94621  
888-883-8742 • 510-865-8742  
john.rafferty@trictools.com  
www.trictools.com

### TROJAN WORLDWIDE INC.

3306 Ella Blvd., Warehouse C  
Houston, TX 77018  
800-392-4902 • 713-692-1140  
info@trojanworldwide.com  
www.trojanworldwide.com

### TRY TEK Machine Works, Inc.

250 N Main St.  
Jacobus, PA 17407  
717-428-1477  
www.trytek.com

## U



### U.S. Boiler Company, Inc.

PO Box 3020  
Lancaster, PA 17603  
888-432-8887 • 717-397-4701  
www.usboiler.net

### United Filters International (UFI)

7932 Ajay Dr.  
Sun Valley, CA 91352  
818-504-9471  
info@unitedfilters.com  
www.unitedfilters.com

### USB-USA

7565 Owl Creek Dr.  
Douglasville, GA 30134  
844-285-5770 • 678-214-7965  
info@usb-usa.com  
www.USB-USA.com

# LittleGIANT<sup>®</sup>

# RATED EASIEST TO INSTALL AMONG CONTRACTORS.

2022 Little Giant Brand Research Study



Safeguarding your property against water damage is crucial, and Little Giant sump pumps provide the reliable defense you need. Offering a range of horsepower, performance, and switch options, these pumps go beyond basic functionality to ensure tailored protection for your home or business.

**Upgrade your defense against water damage today with Little Giant.**



Franklin Electric

[littlegiant.com](http://littlegiant.com)



## V

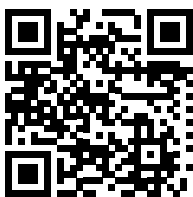

**Vactor Manufacturing**  
1621 S Illinois St.  
Streator, IL 61364  
815-672-3171  
sales@vactor.com  
www.vactor.com

**Viega LLC**  
585 Interlocken Blvd.  
Broomfield, CO 80021  
800-976-9819  
www.viega.us

**Vista Water Group**  
1244 County Rd. 1475  
Ashland, OH 44805  
419-565-5702  
info@vistawatergroup.com  
www.vistawatergroup.com

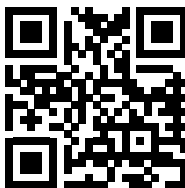

**Vivax-Metrotech Corp.**  
3251 Olcott St.  
Santa Clara, CA 95054  
800-446-3392 • 408-734-1400  
salesUSA@vxmt.com  
www.vxmt.com

Ad on page 53

## W

**Walton Company**  
600 New Park Ave.  
West Hartford, CT 06110  
860-523-5231 • Fax: 860-236-9968  
sales@waltontools.com  
www.waltontools.com

Ad on page 71

**Warrior Trenchless Solutions**  
1400 Commerce Pkwy.  
Lancaster, NY 14086  
716-601-7760  
www.thermoformliner.com

**Western Drain Supply**  
1140 N Kraemer Pl.  
Anaheim, CA 92806  
714-632-0447  
info@westerndrain.com  
www.westerndrain.com

## Z



**Zoeller Company**  
3649 Cane Run Rd.  
Louisville, KY 40211  
502-778-2731  
zotechnical@zoeller.com  
www.zoellerpumps.com

## LISTINGS BY CATEGORY

### ACCESS PANELS

**Dallas Specialty & Mfg. Co.**  
800-222-5644 • www.dallaspecialty.com  
Ad on page 51

**Oatey Co.**  
800-321-9532 • www.oatey.com  
Ad on page 45

**Precision Plumbing Products**  
503-256-4010 • www.ppcinc.net

### ADVANCED TREATMENT UNITS



**Norweco, Inc.**  
800-667-9326 • www.norweco.com

### ALARMS

**SJE Rhombus**  
888-342-5753 • www.sjerrhombus.com

**Zoeller Company**  
502-778-2731 • www.zoellerpumps.com

### BACTERIA - GREASE

**Duracable Manufacturing Co.**  
800-247-4081 • www.duracable.com  
Ad on page 43



**RootX**  
800-844-4974 • www.rootx.com

### BACTERIA - SEPTIC

**Oatey Co.**  
800-321-9532 • www.oatey.com  
Ad on page 45

### BATH/BATH TUBS



**Duravit USA, Inc.**  
770-931-3575 • www.pro.duravit.us/  
Ad on page 9

### BLADES

**Duracable Manufacturing Co.**  
800-247-4081 • www.duracable.com  
Ad on page 43

### BOILERS



**Bradford White Water Heaters**  
215-641-9400 • www.bradfordwhite.com  
Ad on page 47

# “NUFLOW IS THE WHOLE PACKAGE.”

Everything you need to start a successful pipe lining business.

## PIPE LINING TECHNOLOGIES

- NuCure Cold Cure UV
- NuDrain CIPP
- NuTube Inversion

## SUPPORT AND RESOURCES

- The 24/7 support that NuFlow is famous for
- Hands-on technical training from Apprentice to Master
- Tablet with custom jobsite quality assurance software

## ACCESS TO NUFLOW CENTRAL

Online portal that features hundreds of hours of training courses and video content, “Ask an Expert” forum, sales and marketing tools, business resources, as well as support from the entire community of NuFlow Certified Contractors.

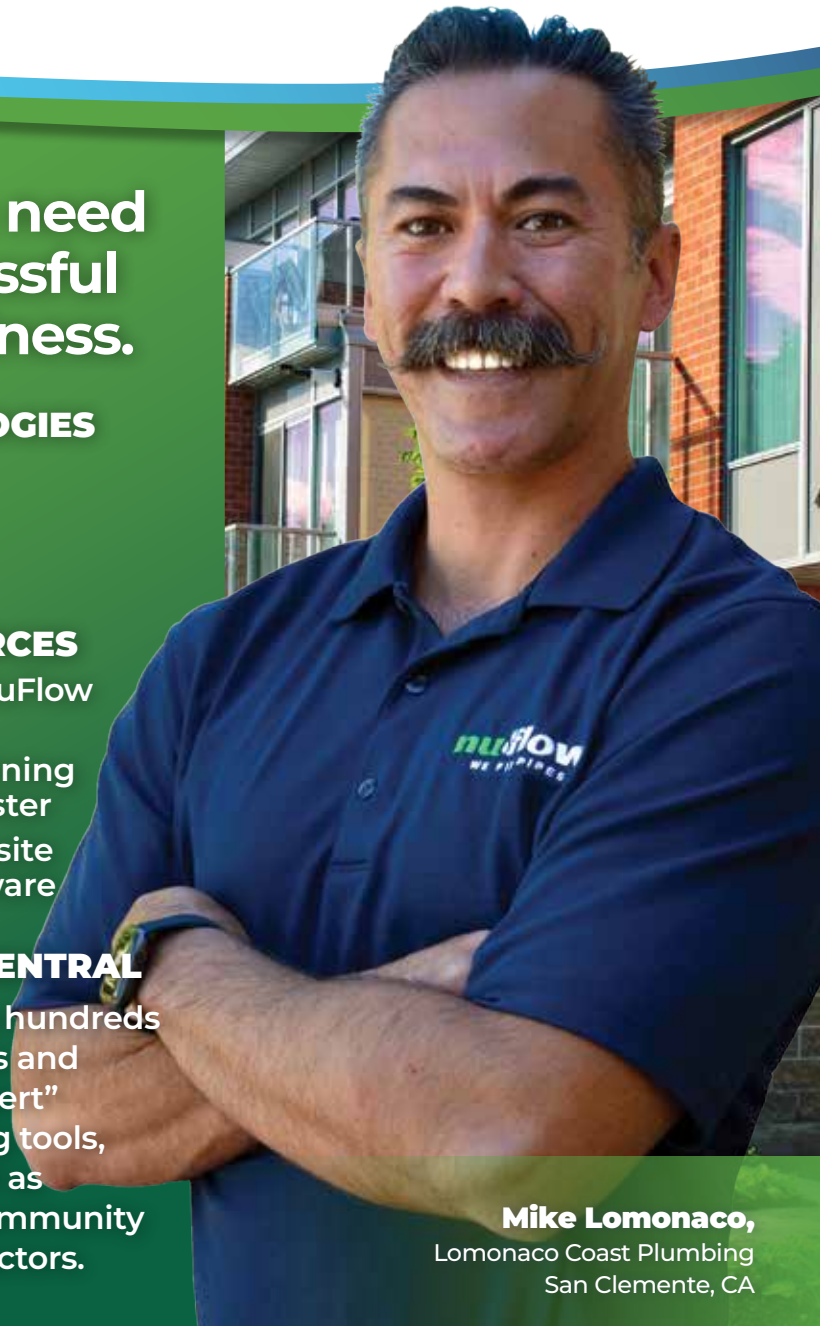

**Mike Lomonaco,**

Lomonaco Coast Plumbing  
San Clemente, CA

**nuflow**  
WE FIX PIPES

[www.nuflow.com](http://www.nuflow.com)  
866-248-6880

Noritz America  
714-422-8120 • [www.noritz.com](http://www.noritz.com)

**SuppliesDepot.com**  
800-359-1334 • [www.suppliesdepot.com](http://www.suppliesdepot.com)  
Ad on page 7



U.S. Boiler Company, Inc.  
888-432-8887 • [www.usboiler.net](http://www.usboiler.net)

Warrior Trenchless Solutions  
716-601-7760 • [www.thermoformliner.com](http://www.thermoformliner.com)

## BORING MACHINES



**ACME Trenchless**  
920-376-4222 • [www.acmetrenchless.com](http://www.acmetrenchless.com)  
Ad on page 67

Pow-r Mole Trenchless Solutions  
800-344-6653 • [www.powrmole.com](http://www.powrmole.com)

## CABLE DRAIN CLEANING MACHINES

**Allan J. Coleman Co.**  
773-728-2400 • [www.allanjcoleman.com](http://www.allanjcoleman.com)  
Ad on page 11

**American Pipelining Supplies**  
888-258-9359 • [www.americanpipeliningsupplies.com](http://www.americanpipeliningsupplies.com)

**Central Oklahoma Winnelson**  
888-947-8761 • [www.centralwinnelson.com](http://www.centralwinnelson.com)  
Ad on page 49

**CPI Products / Cavallero Plastics**  
413-443-0925 • [www.cplproducts.com](http://www.cplproducts.com)

**Duracable Manufacturing Co.**  
800-247-4081 • [www.duracable.com](http://www.duracable.com)  
Ad on page 43

**General PIPE CLEANERS**

**General Pipe Cleaners, div. of General Wire Spring**  
800-245-6200 • [www.drainbrain.com](http://www.drainbrain.com)  
Ad on page 76

**Gorlitz Sewer & Drain, Inc.**  
877-446-7548 • [www.gorlitz.com](http://www.gorlitz.com)

**J.M. McKinney Co.**  
800-821-7275

**MyTana LLC**  
866-735-7684 • [www.mytana.com](http://www.mytana.com)  
Ad on page 61



**Picote Solutions**  
864-940-0088 • [www.picotegroup.com](http://www.picotegroup.com)  
Ad on page 69



## SPARTAN TOOL

**Spartan Tool LLC**  
800-435-3866 • [www.spartantool.com](http://www.spartantool.com)  
Ad on page 2

**TROJAN WORLDWIDE INC.**  
800-392-4902 • [www.trojanworldwide.com](http://www.trojanworldwide.com)

**Western Drain Supply**  
714-632-0447 • [www.westerndrain.com](http://www.westerndrain.com)

## CABLE/CABLE ATTACHMENTS



**ACME Trenchless**  
920-376-4222 • [www.acmetrenchless.com](http://www.acmetrenchless.com)  
Ad on page 67

**American Pipelining Supplies**  
888-258-9359 • [www.americanpipeliningsupplies.com](http://www.americanpipeliningsupplies.com)

**Central Oklahoma Winnelson**  
888-947-8761 • [www.centralwinnelson.com](http://www.centralwinnelson.com)  
Ad on page 49

**Duracable Manufacturing Co.**  
800-247-4081 • [www.duracable.com](http://www.duracable.com)  
Ad on page 43

**EPL Solutions, Inc.**  
714-453-9769 • [www.epls-usa.com](http://www.epls-usa.com)

**General Pipe Cleaners, div. of General Wire Spring**  
800-245-6200 • [www.drainbrain.com](http://www.drainbrain.com)  
Ad on page 76

**Gorlitz Sewer & Drain, Inc.**  
877-446-7548 • [www.gorlitz.com](http://www.gorlitz.com)

**MyTana LLC**  
866-735-7684 • [www.mytana.com](http://www.mytana.com)  
Ad on page 61



## SPARTAN TOOL

**Spartan Tool LLC**  
800-435-3866 • [www.spartantool.com](http://www.spartantool.com)  
Ad on page 2

**TROJAN WORLDWIDE INC.**  
800-392-4902 • [www.trojanworldwide.com](http://www.trojanworldwide.com)

**Western Drain Supply**  
714-632-0447 • [www.westerndrain.com](http://www.westerndrain.com)

## CAMERA TRACTOR WHEELS

**Cua Claws**

**Cua Claws for Resurfacing Camera Wheels**  
714-697-8697 • [www.cuaclaws.com](http://www.cuaclaws.com)  
Ad on page 73



**CUES, Inc.**  
800-327-7791 • [www.cuesinc.com](http://www.cuesinc.com)

**Ratech Electronics, Ltd.**  
800-461-9200 • [www.ratech-electronics.com](http://www.ratech-electronics.com)

## CASING/PIPING/TUBING

**Legend Valve**  
800-752-2082 • [www.legendvalve.com](http://www.legendvalve.com)  
Ad on page 17

## CEMENTS

**Oatey Co.**  
800-321-9532 • [www.oatey.com](http://www.oatey.com)  
Ad on page 45

## CHAIN

**American Pipelining Supplies**  
888-258-9359 • [www.americanpipeliningsupplies.com](http://www.americanpipeliningsupplies.com)

**EPL Solutions, Inc.**  
714-453-9769 • [www.epls-usa.com](http://www.epls-usa.com)



**Picote Solutions**  
864-940-0088 • [www.picotegroup.com](http://www.picotegroup.com)  
Ad on page 69

## CHEMICALS - CLEANING

**Arcan Enterprises**  
888-352-7226 • [www.arcan.com](http://www.arcan.com)  
Ad on page 73

**Milwaukee Rubber Products, Inc.**  
800-325-3730 • [www.milwaukeeerubber.com](http://www.milwaukeeerubber.com)

**Oatey Co.**  
800-321-9532 • [www.oatey.com](http://www.oatey.com)  
Ad on page 45

**Root Rat**  
800-288-7873 • [www.rootrat.net](http://www.rootrat.net)  
Ad on page 73



# THE ONLY THING THAT CAN STOP IT IS... **LUNCH.**

Mongoose Jetters delivers simple, purpose-built jetting equipment designed with the plumbing contractor in mind. Quality equipment, reliable service, and a wide variety of features and options keep our customers operational and profitable. Available in trailer, truck, skid, or van pack, Mongoose Jetters offers any configuration to fit your needs.  
*A serious machine for a serious business.*

- 49 HP turbo diesel engine
- Handheld wireless remote
- 18 GPM @ 4000 PSI water pump
- Rotating 600' x 1/2" capacity hose reel



SALES@MONGOOSEJETTERS.COM / 815.835.5566 / MONGOOSEJETTERS.COM



## CHEMICALS - GREASE

### HotJet USA

800-624-8186 • [www.hotjetusa.com](http://www.hotjetusa.com)

Ad on page 3, 73

Milwaukee Rubber Products, Inc.

800-325-3730 • [www.milwaukeeerubber.com](http://www.milwaukeeerubber.com)

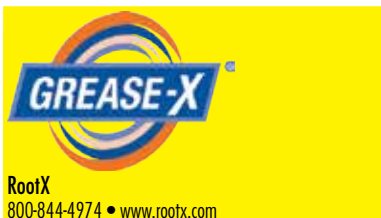

### RootX

800-844-4974 • [www.rootx.com](http://www.rootx.com)

### Root Rat

800-288-7873 • [www.rootrat.net](http://www.rootrat.net)

Ad on page 73

## CIPP EQUIPMENT AND MATERIALS

Alpine Equipment Funding, Inc.

800-640-8660 • [www.alpineequipmentfunding.com](http://www.alpineequipmentfunding.com)



Blackhawk Tech

630-326-9061 • [www.blackhawktchsupply.com](http://www.blackhawktchsupply.com)

## THE SHOOTER®

EMAGINEERED SOLUTIONS INC

541-504-0416 • [www.theshooterlipp.com](http://www.theshooterlipp.com)

EPL Solutions, Inc.

714-453-9769 • [www.epls-usa.com](http://www.epls-usa.com)

FORMADRAIN

888-337-6764 • <https://formadrain.com/>

Ad on page 31



HammerHead Trenchless

800-331-6653 • [www.hammerheadtrenchless.com](http://www.hammerheadtrenchless.com)

Ad on page 33



Infrastructure Repair Systems, Inc.

727-327-4216 • [www.irsi.net](http://www.irsi.net)

JETTERS NORTHWEST

877-901-1936 • [www.jettersonorthwest.com](http://www.jettersonorthwest.com)



MaxLiner

877-426-5948 • [www.maxlinerusa.com](http://www.maxlinerusa.com)

Ad on page 75

NuFlow Technologies

866-430-2134 • [www.nuflow.com](http://www.nuflow.com)

Ad on page 37



Picote Solutions

864-940-0088 • [www.picotegroup.com](http://www.picotegroup.com)

Ad on page 69



Pipeline Renewal Technologies

866-936-8476 • [www.pipelinet.com](http://www.pipelinet.com)

Ad on page 65

Source ONE Environmental

877-450-3701 • [www.s1eonline.com](http://www.s1eonline.com)

TRY TEK Machine Works, Inc.

717-428-1477 • [www.trytek.com](http://www.trytek.com)

Warrior Trenchless Solutions

716-601-7760 • [www.thermoformliner.com](http://www.thermoformliner.com)

Western Drain Supply

714-632-0447 • [www.westerndrain.com](http://www.westerndrain.com)

## CLAMPS

Dallas Specialty & Mfg. Co.

800-222-5644 • [www.dallasspecialty.com](http://www.dallasspecialty.com)

Ad on page 51

## COATINGS/LININGS/ SEALANTS

American Pipelining Supplies

888-258-9359 • [www.americanpipeliningsupplies.com](http://www.americanpipeliningsupplies.com)

EPL Solutions, Inc.

714-453-9769 • [www.epls-usa.com](http://www.epls-usa.com)

Infrastructure Repair Systems, Inc.

727-327-4216 • [www.irsi.net](http://www.irsi.net)



Picote Solutions

864-940-0088 • [www.picotegroup.com](http://www.picotegroup.com)

Ad on page 69

Source ONE Environmental

877-450-3701 • [www.s1eonline.com](http://www.s1eonline.com)

Warrior Trenchless Solutions

716-601-7760 • [www.thermoformliner.com](http://www.thermoformliner.com)

## COMMERCIAL ONSITE TREATMENT SYSTEMS

Crane Pumps & Systems

937-773-2442 • [www.cranepumps.com](http://www.cranepumps.com)

Ad on page 23

Norweco, Inc.

800-667-9326 • [www.norweco.com](http://www.norweco.com)

## CONNECTORS - WATER & GAS

Legend Valve

800-752-2082 • [www.legendvalve.com](http://www.legendvalve.com)

Ad on page 17

## CONTROLS

AquaMotion, Inc.

401-785-3000 • [www.aquamotionhvac.com](http://www.aquamotionhvac.com)

Legend Valve

800-752-2082 • [www.legendvalve.com](http://www.legendvalve.com)

Ad on page 17

Liberty Pumps

800-543-2550 • [www.LibertyPumps.com](http://www.LibertyPumps.com)

Ad on page 41

REHAU Construction

800-247-9445 • [www.na.rehau.com](http://www.na.rehau.com)

SJE Rhombus

888-342-5753 • [www.sjehombus.com](http://www.sjehombus.com)

Zoeller Company

502-778-2731 • [www.zoellerpumps.com](http://www.zoellerpumps.com)

## COUPLINGS - PIPE

Arrowhead Brass

800-332-4267 • [www.arrowheadbrass.com](http://www.arrowheadbrass.com)

# Compact. Quiet.

## The Model 406 Drain Pump



- Small compact size
- Fits in tight areas
- Quiet performance
- Upper and lower inlets
- Attractive appliance-style design

# Liberty Pumps®

A Family and Employee Owned Company

800-543-2550 - [LibertyPumps.com](http://LibertyPumps.com)

Copyright © Liberty Pumps, Inc. 2024 All rights reserved.



Perfect for mounting in cabinets



**Dallas Specialty & Mfg. Co.**  
800-222-5644 • [www.dallasspecialty.com](http://www.dallasspecialty.com)  
Ad on page 51

**REHAU Construction**  
800-247-9445 • [www.na.rehau.com](http://www.na.rehau.com)

**Source ONE Environmental**  
877-450-3701 • [www.s1eonline.com](http://www.s1eonline.com)

## CRANES/HOISTS

**SalesMaker Carts**  
800-821-4140 • [www.salesmakercarts.com](http://www.salesmakercarts.com)  
Ad on page 65

**SpitzLift Manufacturing**  
619-713-5061 • [www.spitzlift.com](http://www.spitzlift.com)

## DEALER/DISTRIBUTOR

**Corro-Protec**  
877-466-6660 • [www.corroprotec.com/product/water-heater-anode-rod](http://www.corroprotec.com/product/water-heater-anode-rod)

**EPL Solutions, Inc.**  
714-453-9769 • [www.epls-usa.com](http://www.epls-usa.com)

## DISINFECTION EQUIPMENT/ SYSTEMS

**IntelliHot Inc.**  
866-692-6791 • [www.intellihot.com](http://www.intellihot.com)

**Norweco, Inc.**  
800-667-9326 • [www.norweco.com](http://www.norweco.com)

## DRAINFIELD COMPONENTS

**Arcan Enterprises**  
888-352-7226 • [www.arcan.com](http://www.arcan.com)  
Ad on page 73

**CPI Products / Cavallero Plastics**  
413-443-0925 • [www.cplproducts.com](http://www.cplproducts.com)

## DRAINS

**CPI Products / Cavallero Plastics**  
413-443-0925 • [www.cplproducts.com](http://www.cplproducts.com)

**Dallas Specialty & Mfg. Co.**  
800-222-5644 • [www.dallasspecialty.com](http://www.dallasspecialty.com)  
Ad on page 51

## DURAVIT



**Duravit USA, Inc.**  
770-931-3575 • [www.pro.duravit.us/](http://www.pro.duravit.us/)  
Ad on page 9

**FORMADRAIN**  
888-337-6764 • <https://formadrain.com/>  
Ad on page 31

**Oatey Co.**  
800-321-9532 • [www.oatey.com](http://www.oatey.com)  
Ad on page 45

**PRIER Products**  
800-362-9055 • [www.prier.com](http://www.prier.com)  
Ad on page 25

**Vista Water Group**  
419-565-5702 • [www.vistawatergroup.com](http://www.vistawatergroup.com)

## DRIP SYSTEMS

**Norweco, Inc.**  
800-667-9326 • [www.norweco.com](http://www.norweco.com)

## EDUCATION/TRAINING

**AQUAGUARD LLC**  
844-438-9247 • [www.wagsvalve.com](http://www.wagsvalve.com)  
Ad on page 51

**Legend Valve**  
800-752-2082 • [www.legendvalve.com](http://www.legendvalve.com)  
Ad on page 17

**MaxLiner**  
877-426-5948 • [www.maxlinerusa.com](http://www.maxlinerusa.com)  
Ad on page 75

**NuFlow Technologies**  
866-430-2134 • [www.nuflow.com](http://www.nuflow.com)  
Ad on page 37

## EXCAVATING EQUIPMENT

**ACME TRENCHLESS**  
**ACME Trenchless**  
920-376-4222 • [www.acmetrenchless.com](http://www.acmetrenchless.com)  
Ad on page 67

**Hydra-Flex, Inc.**  
952-808-3640 • [www.hydraflexinc.com](http://www.hydraflexinc.com)

**Suttner America Company**  
800-831-0660 • [www.suttner.com](http://www.suttner.com)

## FAUCETS

## DURAVIT



**Duravit USA, Inc.**  
770-931-3575 • [www.pro.duravit.us/](http://www.pro.duravit.us/)  
Ad on page 9

**PRIER Products**  
800-362-9055 • [www.prier.com](http://www.prier.com)  
Ad on page 25

**SuppliesDepot.com**  
800-359-1334 • [www.suppliesdepot.com](http://www.suppliesdepot.com)  
Ad on page 7

## FILTRATION EQUIPMENT/ SYSTEMS

**Aqua-Rex LLC**  
877-640-2170 • [www.aqua-rex.com](http://www.aqua-rex.com)  
Ad on page 27

**ENPRESS LLC**  
*Where Innovation Flows™*  
**ENPRESS LLC**  
866-859-9274 • [www.enpress.com](http://www.enpress.com)  
Ad on page 22

**Norweco, Inc.**  
800-667-9326 • [www.norweco.com](http://www.norweco.com)

**SuppliesDepot.com**  
800-359-1334 • [www.suppliesdepot.com](http://www.suppliesdepot.com)  
Ad on page 7

**UFI**  
**UNITED FILTERS INTERNATIONAL**  
an ENPRESS Company  
**United Filters International (UFI)**  
818-504-9471 • [www.unitedfilters.com](http://www.unitedfilters.com)

## FIRE PROTECTION

**REHAU Construction**  
800-247-9445 • [www.na.rehau.com](http://www.na.rehau.com)

## FITTINGS

**Arrowhead Brass**  
800-332-4267 • [www.arrowheadbrass.com](http://www.arrowheadbrass.com)

DURACABLE DALE



WORDS OF WISDOM

NOTHING VENTURED  
NOTHING  
DRAINED

IT'S TIME TO TRY DURACABLE.



DURACABLE®

MANUFACTURING

— CO —

800-247-4081

DURACABLE.COM

RIGHT IN THERE WITH YOU.

## ClearLOC

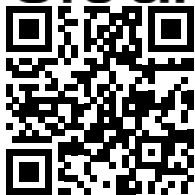

### Legend Valve

800-752-2082 • [www.legendvalve.com](http://www.legendvalve.com)

Ad on page 17

### Precision Plumbing Products

503-256-4010 • [www.ppcinc.net](http://www.ppcinc.net)

### REHAU Construction

800-247-9445 • [www.na.rehau.com](http://www.na.rehau.com)

### SuppliesDepot.com

800-359-1334 • [www.suppliesdepot.com](http://www.suppliesdepot.com)

Ad on page 7

### Suttner America Company

800-831-0660 • [www.suttner.com](http://www.suttner.com)

### Vista Water Group

419-565-5702 • [www.vistawatergroup.com](http://www.vistawatergroup.com)

## FIXTURES - PLUMBING

### Arrowhead Brass

800-332-4267 • [www.arrowheadbrass.com](http://www.arrowheadbrass.com)

### Saniflo SFA Inc.

800-571-8191 • [www.saniflo.com](http://www.saniflo.com)

### SuppliesDepot.com

800-359-1334 • [www.suppliesdepot.com](http://www.suppliesdepot.com)

Ad on page 7

## FLANGES

### Dallas Specialty & Mfg. Co.

800-222-5644 • [www.dallasspecialty.com](http://www.dallasspecialty.com)

Ad on page 51

### Legend Valve

800-752-2082 • [www.legendvalve.com](http://www.legendvalve.com)

Ad on page 17

## FLOW/LEVEL SWITCHES

### General Pump

888-474-5487 • [www.generalpump.com](http://www.generalpump.com)

### SJE Rhombus

888-342-5753 • [www.sjrhombus.com](http://www.sjrhombus.com)

## GARBAGE DISPOSALS

### SuppliesDepot.com

800-359-1334 • [www.suppliesdepot.com](http://www.suppliesdepot.com)

Ad on page 7

## GAS EQUIPMENT

### Hermann Sewerin GmbH

888-592-9916 • [www.sewerin.net](http://www.sewerin.net)

Ad on page 49

### Milwaukee Rubber Products, Inc.

800-325-3730 • [www.milwaukeeerubber.com](http://www.milwaukeeerubber.com)

## GAUGES

### Legend Valve

800-752-2082 • [www.legendvalve.com](http://www.legendvalve.com)

Ad on page 17

### Mongoose Jettors by Sewer Equipment

877-735-4640 • [www.sewerequipment.com/mongoose-jettors](http://www.sewerequipment.com/mongoose-jettors)

Ad on page 39

## GEOHERMAL HEATING

### AquaMotion, Inc.

401-785-3000 • [www.aquamotionhvac.com](http://www.aquamotionhvac.com)

### REHAU Construction

800-247-9445 • [www.na.rehau.com](http://www.na.rehau.com)

## GREASE INTERCEPTORS

### SuppliesDepot.com

800-359-1334 • [www.suppliesdepot.com](http://www.suppliesdepot.com)

Ad on page 7

## HAND TOOLS

### Qescorp d/b/a DiscountSawBlade.com

888-641-9798 • [www.discountawblade.com](http://www.discountawblade.com)

Ad on page 71

### Walton Company

860-523-5231 • [www.waltontools.com](http://www.waltontools.com)

Ad on page 71

## HEAT TRANSFER EQUIPMENT

### Legend Valve

800-752-2082 • [www.legendvalve.com](http://www.legendvalve.com)

Ad on page 17

## HEATERS

### Arctic Blaster, Inc.

403-636-1488 • [www.arcticblaster.com](http://www.arcticblaster.com)

### Easy-Kleen Pressure Systems Ltd.

800-315-5533 • [www.easyleen.com](http://www.easyleen.com)

Ad on page 67

### Heat-flo

508-278-2400 • [www.heat-flo.com](http://www.heat-flo.com)

Ad on page 57

## HEATERS - WATER

### AQUAGUARD



### AQUAGUARD LLC

844-438-9247 • [www.wagsvalve.com](http://www.wagsvalve.com)

Ad on page 51



### Bradford White Water Heaters

215-641-9400 • [www.bradfordwhite.com](http://www.bradfordwhite.com)

Ad on page 47

### Corro-Protec

877-466-6660 • [www.corroprotec.com](http://www.corroprotec.com)

### Heat-flo

508-278-2400 • [www.heat-flo.com](http://www.heat-flo.com)

Ad on page 57

### IntelliHot Inc.

866-692-6791 • [www.intellihot.com](http://www.intellihot.com)

### Noritz America

714-422-8120 • [www.noritz.com](http://www.noritz.com)

### SalesMaker Carts

800-821-4140 • [www.salesmakercarts.com](http://www.salesmakercarts.com)

Ad on page 65

### SuppliesDepot.com

800-359-1334 • [www.suppliesdepot.com](http://www.suppliesdepot.com)

Ad on page 7

## HOSE - HIGH PRESSURE

### Allan J. Coleman Co.

773-728-2400 • [www.allanjcoleman.com](http://www.allanjcoleman.com)

Ad on page 11

### American Jetter

866-944-3569 • [www.americanjetter.com](http://www.americanjetter.com)

Ad on page 73



### Dyna Flex, Inc.

440-946-9424 • [www.dynaflexinc.com](http://www.dynaflexinc.com)

### Easy-Kleen Pressure Systems Ltd.

800-315-5533 • [www.easyleen.com](http://www.easyleen.com)

Ad on page 67

### EPL Solutions, Inc.

714-453-9769 • [www.epls-usa.com](http://www.epls-usa.com)

### JETTERS NORTHWEST

877-901-1936 • [www.jettersnorthwest.com](http://www.jettersnorthwest.com)

### Milwaukee Rubber Products, Inc.

800-325-3730 • [www.milwaukeeerubber.com](http://www.milwaukeeerubber.com)

### Mongoose Jettors by Sewer Equipment

877-735-4640 • [www.sewerequipment.com/mongoose-jettors](http://www.sewerequipment.com/mongoose-jettors)

Ad on page 39

### MyTana LLC

866-735-7684 • [www.mytana.com](http://www.mytana.com)

Ad on page 61

New washer  
installation  
7-5-86  
George & Sue



# Cementing Legacies

When you choose Oatey, you choose a name backed by more than a century of excellence in the plumbing industry. With specialty formulas that address the needs of every solvent weld application, Oatey gives you the confidence in knowing you're not just welding pipes – **you're creating a bond for life.**

**Oatey**<sup>®</sup>

## Root Rat

800-288-7873 • [www.rootrat.net](http://www.rootrat.net)

Ad on page 73

## Shamrock Nozzles By Triton HydroTools

800-633-7696 • [www.shamrocktools.com](http://www.shamrocktools.com)

## Suttner America Company

800-831-0660 • [www.suttner.com](http://www.suttner.com)

## TROJAN WORLDWIDE INC.

800-392-4902 • [www.trojanworldwide.com](http://www.trojanworldwide.com)

## Western Drain Supply

714-632-0447 • [www.westernrain.com](http://www.westernrain.com)

## HOSE - INDUSTRIAL

### Milwaukee Rubber Products, Inc.

800-325-3730 • [www.milwaukeeerubber.com](http://www.milwaukeeerubber.com)

## HOSE REELS

### Easy-Kleen Pressure Systems Ltd.

800-315-5533 • [www.easycleen.com](http://www.easycleen.com)

Ad on page 67

### General Pump

888-474-5487 • [www.generalpump.com](http://www.generalpump.com)

### JETTERS NORTHWEST

877-901-1936 • [www.jettersonorthwest.com](http://www.jettersonorthwest.com)

### Milwaukee Rubber Products, Inc.

800-325-3730 • [www.milwaukeeerubber.com](http://www.milwaukeeerubber.com)

### Mongoose Jettors by Sewer Equipment

877-735-4640 • [www.sewerequipment.com/mongoosejettors](http://www.sewerequipment.com/mongoosejettors)

Ad on page 39

### Suttner America Company

800-831-0660 • [www.suttner.com](http://www.suttner.com)

### Vactor Manufacturing

815-672-3171 • [www.vactor.com](http://www.vactor.com)

## HYDRANTS

### Arrowhead Brass

800-332-4267 • [www.arrowheadbrass.com](http://www.arrowheadbrass.com)

### PRIER Products

800-362-9055 • [www.prier.com](http://www.prier.com)

Ad on page 25

## HYDRONIC HEATING

### AquaMotion, Inc.

401-785-3000 • [www.aquamotionhvac.com](http://www.aquamotionhvac.com)

### Bradford White Water Heaters

215-641-9400 • [www.bradfordwhite.com](http://www.bradfordwhite.com)

Ad on page 47

### Heat-flo

508-278-2400 • [www.heat-flo.com](http://www.heat-flo.com)

Ad on page 57

### Legend Valve

800-752-2082 • [www.legendvalve.com](http://www.legendvalve.com)

Ad on page 17

### Precision Plumbing Products

503-256-4010 • [www.ppcinc.net](http://www.ppcinc.net)

### REHAU Construction

800-247-9445 • [www.na.rehau.com](http://www.na.rehau.com)

### SuppliesDepot.com

800-359-1334 • [www.suppliesdepot.com](http://www.suppliesdepot.com)

Ad on page 7

### U.S. Boiler Company, Inc.

888-432-8887 • [www.usboiler.net](http://www.usboiler.net)

## INSPECTION - DRAINLINE

### Allan J. Coleman Co.

773-728-2400 • [www.allancoleman.com](http://www.allancoleman.com)

Ad on page 11

### Alpine Equipment Funding, Inc.

800-640-8660 • [www.alpineequipmentfunding.com](http://www.alpineequipmentfunding.com)

### American Pipelining Supplies

888-258-9359 • [www.americanpipeliningsupplies.com](http://www.americanpipeliningsupplies.com)

### Central Oklahoma Winnelson

888-947-8761 • [www.centralwinnelson.com](http://www.centralwinnelson.com)

Ad on page 49

### Cherne Industries

800-843-7584 • [www.cherneind.com](http://www.cherneind.com)

### CPI Products / Cavallero Plastics

413-443-0925 • [www.cplproducts.com](http://www.cplproducts.com)



### CUES, Inc.

800-327-7791 • [www.cuesinc.com](http://www.cuesinc.com)

### EasyCAM

239-260-2056 • [www.easycamllc.com](http://www.easycamllc.com)

### EPL Solutions, Inc.

714-453-9769 • [www.epls-usa.com](http://www.epls-usa.com)

### FORMADRAIN

888-337-6764 • <https://formadrain.com/>

Ad on page 31

## General PIPE CLEANERS

### General Pipe Cleaners, div. of General Wire Spring

800-245-6200 • [www.drainbrain.com](http://www.drainbrain.com)

Ad on page 76

### Gorlitz Sewer & Drain, Inc.

877-446-7548 • [www.gorlitz.com](http://www.gorlitz.com)

### Insight Vision Cameras

800-488-8177 • [www.goinsightvision.com](http://www.goinsightvision.com)

### J.M. McKinney Co.

800-821-7275

### JETTERS NORTHWEST

877-901-1936 • [www.jettersonorthwest.com](http://www.jettersonorthwest.com)

### MyTana LLC

866-735-7684 • [www.mytana.com](http://www.mytana.com)

Ad on page 61

### Pow-r Mole Trenchless Solutions

800-344-6653 • [www.powrmole.com](http://www.powrmole.com)

### Ratech Electronics, Ltd.

800-461-9200 • [www.ratech-electronics.com](http://www.ratech-electronics.com)

### RauschUSA

877-728-7241 • [www.rauschusa.com](http://www.rauschusa.com)

Ad on page 55



## SPARTAN TOOL

### Spartan Tool LLC

800-435-3866 • [www.spartantool.com](http://www.spartantool.com)

Ad on page 2

### Superior Signal Company LLC

732-251-0800 • [www.SuperiorSignal.com/PLBG](http://www.SuperiorSignal.com/PLBG)

Ad on page 73

### TROJAN WORLDWIDE INC.

800-392-4902 • [www.trojanworldwide.com](http://www.trojanworldwide.com)



### VIVAX

### METROTECH

### Vivax-Metrotech Corp.

800-446-3392 • [www.vxmt.com](http://www.vxmt.com)

Ad on page 53

## INSPECTION - LATERAL

### Allan J. Coleman Co.

773-728-2400 • [www.allancoleman.com](http://www.allancoleman.com)

Ad on page 11

### Alpine Equipment Funding, Inc.

800-640-8660 • [www.alpineequipmentfunding.com](http://www.alpineequipmentfunding.com)

### American Pipelining Supplies

888-258-9359 • [www.americanpipeliningsupplies.com](http://www.americanpipeliningsupplies.com)

### Cherne Industries

800-843-7584 • [www.cherneind.com](http://www.cherneind.com)

### CPI Products / Cavallero Plastics

413-443-0925 • [www.cplproducts.com](http://www.cplproducts.com)



## CUES

### CUES, Inc.

800-327-7791 • [www.cuesinc.com](http://www.cuesinc.com)

### EasyCAM

239-260-2056 • [www.easycamllc.com](http://www.easycamllc.com)

### EPL Solutions, Inc.

714-453-9769 • [www.epls-usa.com](http://www.epls-usa.com)

### Insight Vision Cameras

800-488-8177 • [www.goinsightvision.com](http://www.goinsightvision.com)



### MyTana LLC

866-735-7684 • [www.mytana.com](http://www.mytana.com)

Ad on page 61



**SPECIAL PROMO: Get a FREE Service Parts Kit (\$1,290 Value)**

when you purchase any 4 Infiniti® GS & GR tankless water heaters between April 1st and June 30th.

Details at [forthe.pro.bradfordwhite.com/tanklesstreasure](https://forthe.pro.bradfordwhite.com/tanklesstreasure)



# THE ULTIMATE TANKLESS SOLUTION

Every contractor needs a go-to tankless that can tackle just about any job. That's what we had in mind when we engineered the **Infiniti® GS & GR** tankless gas water heaters.

They're flexible and easy to install in many configurations.

- Robust stainless steel heat exchanger for longer life
- Residential and Commercial applications (Indoor/Outdoor)
- Cascade and common venting between standard and recirculation models
- ENERGY STAR® certified and Certified Green Product™ by the Green Restaurant Association



See how we built  
a better tankless

  
**BRADFORD WHITE**<sup>®</sup>  
WATER HEATERS  
Built to be the Best<sup>®</sup>

## PEARPOINT

Pearpoint Inc.  
800-688-8094 • www.pearpoint.com

Pow-r Mole Trenchless Solutions  
800-344-6653 • www.powrmole.com

Ratech Electronics, Ltd.  
800-461-9200 • www.ratech-electronics.com

RauschUSA  
877-728-7241 • www.rauschusa.com  
Ad on page 55

Source ONE Environmental  
877-450-3701 • www.s1eonline.com

Superior Signal Company LLC  
732-251-0800 • www.SuperiorSignal.com/PLBG

Ad on page 73



**VIVAX**  
**METROTECH**

Vivax-Metrotech Corp.  
800-446-3392 • www.vxmt.com  
Ad on page 53

## INSPECTION - MAINLINE

Alpine Equipment Funding, Inc.  
800-640-8660 • www.alpineequipmentfunding.com

American Pipelining Supplies  
888-258-9359 • www.americanpipeliningsupplies.com

CPI Products / Cavallero Plastics  
413-443-0925 • www.cplproducts.com



CUES, Inc.  
800-327-7791 • www.cuesinc.com

EasyCAM  
239-260-2056 • www.easycamllc.com

EPL Solutions, Inc.  
714-453-9769 • www.epls-usa.com

Gorlitz Sewer & Drain, Inc.  
877-446-7548 • www.gorlitz.com

Insight Vision Cameras  
800-488-8177 • www.gainsightvision.com

J.M. McKinney Co.  
800-821-7275

MyTana LLC  
866-735-7684 • www.mytana.com  
Ad on page 61

## PEARPOINT

Pearpoint Inc.  
800-688-8094 • www.pearpoint.com

Ratech Electronics, Ltd.  
800-461-9200 • www.ratech-electronics.com

RauschUSA  
877-728-7241 • www.rauschusa.com  
Ad on page 55

Superior Signal Company LLC  
732-251-0800 • www.SuperiorSignal.com/PLBG  
Ad on page 73

TROJAN WORLDWIDE INC.  
800-392-4902 • www.trojanworldwide.com

## INSPECTION - WATER LINES

Alpine Equipment Funding, Inc.  
800-640-8660 • www.alpineequipmentfunding.com

Central Oklahoma Winnelson  
888-947-8761 • www.centralwinnelson.com  
Ad on page 49

Cherne Industries  
800-843-7584 • www.cherneind.com

CPI Products / Cavallero Plastics  
413-443-0925 • www.cplproducts.com



CUES, Inc.  
800-327-7791 • www.cuesinc.com

EasyCAM  
239-260-2056 • www.easycamllc.com

EPL Solutions, Inc.  
714-453-9769 • www.epls-usa.com

Ratech Electronics, Ltd.  
800-461-9200 • www.ratech-electronics.com

RauschUSA  
877-728-7241 • www.rauschusa.com  
Ad on page 55

## INSURANCE

Progressive Insurance  
800-776-4737 • www.progressivecommercial.com  
Ad on page 19

## JETTERS - PORTABLE

Allan J. Coleman Co.  
773-728-2400 • www.allanjcoleman.com  
Ad on page 11

Alpine Equipment Funding, Inc.  
800-640-8660 • www.alpineequipmentfunding.com

American Jetter  
866-944-3569 • www.americanjetter.com  
Ad on page 73

American Pipelining Supplies  
888-258-9359 • www.americanpipeliningsupplies.com



Cam Spray  
800-648-5011 • www.camspray.com  
Ad on page 15

Central Oklahoma Winnelson  
888-947-8761 • www.centralwinnelson.com  
Ad on page 49

Easy-Kleen Pressure Systems Ltd.  
800-315-5533 • www.easykleen.com  
Ad on page 67

EPL Solutions, Inc.  
714-453-9769 • www.epls-usa.com

**General**  
**PIPE CLEANERS**  
General Pipe Cleaners,  
div. of General Wire Spring  
800-245-6200 • www.drainbrain.com  
Ad on page 76

Gorlitz Sewer & Drain, Inc.  
877-446-7548 • www.gorlitz.com

HotJet USA  
800-624-8186 • www.hotjetusa.com  
Ad on page 3, 73

J.M. McKinney Co.  
800-821-7275



JETTTERS NORTHWEST  
877-901-1936 • www.jetttersnorthwest.com



MyTana LLC  
866-735-7684 • www.mytana.com  
Ad on page 61

Root Rat  
800-288-7873 • www.rootrat.net  
Ad on page 73



## SPARTAN TOOL

Spartan Tool LLC  
800-435-3866 • www.spartantool.com  
Ad on page 2

TROJAN WORLDWIDE INC.  
800-392-4902 • www.trojanworldwide.com

Vector Manufacturing  
815-672-3171 • www.vector.com

Western Drain Supply  
714-632-0447 • www.westerndrain.com

## JETTERS - TRUCK & TRAILER

Allan J. Coleman Co.  
773-728-2400 • www.allanjcoleman.com  
Ad on page 11

Alpine Equipment Funding, Inc.  
800-640-8660 • www.alpineequipmentfunding.com

While others are still searching...  
...WE ARE FINDING LEAKS!



**SeCorrPhon AC 200 & VARIOTEC® 460 Tracergas**  
EVERYTHING you need on non-metallic pipes!

Hermann Sewerin GmbH | Office +1 888 592 9916 | Cell +1 888 592 9916 ext. 103 | sewerin-usa@sewerin.net | www.sewerin.com

**YOUR SOURCE FOR  
RIDGID**

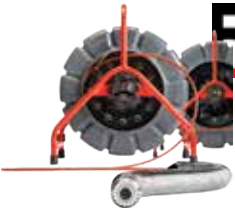

**SeeSnake® TruSense™  
Camera Reel**



**CS12x Digital  
Reporting Monitor\***



**Flexshaft  
K9-102, K9-204**



**SeeSnake® Compact M40  
Camera System**



**CS65x Digital  
Reporting Monitor\***



**SeeSnake®  
MAX rM200  
Camera System**



**microDrain Reel**



**CS6xVersa Digital  
Recording Monitor\***

\*With Wi-Fi



**8% ONE YEAR FINANCING AVAILABLE!**  
Longer lease rates also available. Call Keith for details.

**BUYING A SEESNAKE?**

**CALL US FOR  
GREAT PRICING &  
FREE SHIPPING!**

**WE  
WILL NOT BE  
UNDERSOLD**

**– Call Evenings and Weekends – Keith: 405-602-9155  
– Ryan: 719-243-3539**

**CALL TOLL FREE: 888-947-8761**

5037 NW 10th • Oklahoma City, OK 73127

**www.centralwinnelson.com**

## American Jetter

866-944-3569 • [www.americanjetter.com](http://www.americanjetter.com)

Ad on page 73

## American Pipelining Supplies

888-258-9359 • [www.americanpipeliningsupplies.com](http://www.americanpipeliningsupplies.com)



## Cam Spray

800-648-5011 • [www.camspray.com](http://www.camspray.com)

Ad on page 15

## Easy-Kleen Pressure Systems Ltd.

800-315-5533 • [www.easycleen.com](http://www.easycleen.com)

Ad on page 67

## EPL Solutions, Inc.

714-453-9769 • [www.epls-usa.com](http://www.epls-usa.com)

## General Pipe Cleaners, div. of General Wire Spring

800-245-6200 • [www.drainbrain.com](http://www.drainbrain.com)

Ad on page 76

## HotJet USA

800-624-8186 • [www.hotjetusa.com](http://www.hotjetusa.com)

Ad on page 3, 73

## JETTERS NORTHWEST

877-901-1936 • [www.jettersonorthwest.com](http://www.jettersonorthwest.com)

## Mongoose Jetters by Sewer Equipment

877-735-4640 • [www.sewerequipment.com/mongoose-jetters](http://www.sewerequipment.com/mongoose-jetters)

Ad on page 39

## MyTana LLC

866-735-7684 • [www.mytana.com](http://www.mytana.com)

Ad on page 61

## Root Rat

800-288-7873 • [www.rootrat.net](http://www.rootrat.net)

Ad on page 73



## SPARTAN TOOL

### Spartan Tool LLC

800-435-3866 • [www.spartantool.com](http://www.spartantool.com)

Ad on page 2

## TROJAN WORLDWIDE INC.

800-392-4902 • [www.trojanworldwide.com](http://www.trojanworldwide.com)

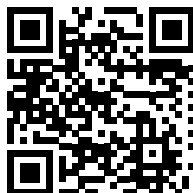

## Vactor Manufacturing

815-672-3171 • [www.vactor.com](http://www.vactor.com)

## LEAD WATER LINE REPLACEMENT EQUIPMENT

### ACME<sup>®</sup> TRENCHLESS

#### ACME Trenchless

920-376-4222 • [www.acmetrenchless.com](http://www.acmetrenchless.com)

Ad on page 67

## LEAK DETECTION EQUIPMENT

### Alpine Equipment Funding, Inc.

800-640-8660 • [www.alpineequipmentfunding.com](http://www.alpineequipmentfunding.com)

### American Pipelining Supplies

888-258-9359 • [www.americanpipeliningsupplies.com](http://www.americanpipeliningsupplies.com)



## Cherne Industries

800-843-7584 • [www.cherneind.com](http://www.cherneind.com)

## General Pipe Cleaners, div. of General Wire Spring

800-245-6200 • [www.drainbrain.com](http://www.drainbrain.com)

Ad on page 76

## Hermann Sewerin GmbH

888-592-9916 • [www.sewerin.net](http://www.sewerin.net)

Ad on page 49

## J.M. McKinney Co.

800-821-7275

## Source ONE Environmental

877-450-3701 • [www.s1eonline.com](http://www.s1eonline.com)

## Superior Signal Company LLC

732-251-0800 • [www.SuperiorSignal.com/PLBG](http://www.SuperiorSignal.com/PLBG)

Ad on page 73

## LEASING/FINANCING

### Alpine Equipment Funding, Inc.

800-640-8660 • [www.alpineequipmentfunding.com](http://www.alpineequipmentfunding.com)

## LIFT STATIONS/WET WELLS

### Crane Pumps & Systems

937-773-2442 • [www.cranepumps.com](http://www.cranepumps.com)

Ad on page 23

### Liberty Pumps

800-543-2550 • [www.LibertyPumps.com](http://www.LibertyPumps.com)

Ad on page 41

### Saniflo SFA Inc.

800-571-8191 • [www.saniflo.com](http://www.saniflo.com)

## Zoeller Company

502-778-2731 • [www.zoellerpumps.com](http://www.zoellerpumps.com)

## LOCATORS - ELECTRONIC

### American Pipelining Supplies

888-258-9359 • [www.americanpipeliningsupplies.com](http://www.americanpipeliningsupplies.com)

### Central Oklahoma Winnelson

888-947-8761 • [www.centralwinnelson.com](http://www.centralwinnelson.com)

Ad on page 49

### EPL Solutions, Inc.

714-453-9769 • [www.epls-usa.com](http://www.epls-usa.com)

## General Pipe Cleaners, div. of General Wire Spring

800-245-6200 • [www.drainbrain.com](http://www.drainbrain.com)

Ad on page 76

## Hermann Sewerin GmbH

888-592-9916 • [www.sewerin.net](http://www.sewerin.net)

Ad on page 49

## Pow-r Mole Trenchless Solutions

800-344-6653 • [www.powrmole.com](http://www.powrmole.com)



## VIVAX METROTECH

### Vivax-Metrotech Corp.

800-446-3392 • [www.vxmt.com](http://www.vxmt.com)

Ad on page 53

## LOCATORS - PIPE/LEAK/ VALVE/SEWER

### Allan J. Coleman Co.

773-728-2400 • [www.allanjcoleman.com](http://www.allanjcoleman.com)

Ad on page 11

### American Pipelining Supplies

888-258-9359 • [www.americanpipeliningsupplies.com](http://www.americanpipeliningsupplies.com)

### Central Oklahoma Winnelson

888-947-8761 • [www.centralwinnelson.com](http://www.centralwinnelson.com)

Ad on page 49

### Cherne Industries

800-843-7584 • [www.cherneind.com](http://www.cherneind.com)

### EasyCAM

239-260-2056 • [www.easycamlc.com](http://www.easycamlc.com)

### EPL Solutions, Inc.

714-453-9769 • [www.epls-usa.com](http://www.epls-usa.com)

## General Pipe Cleaners, div. of General Wire Spring

800-245-6200 • [www.drainbrain.com](http://www.drainbrain.com)

Ad on page 76

## Hermann Sewerin GmbH

888-592-9916 • [www.sewerin.net](http://www.sewerin.net)

Ad on page 49

## J.M. McKinney Co.

800-821-7275

## Lansas Mfg. by Vanderlans & Sons Inc.

800-452-4902 • [www.lansas.com](http://www.lansas.com)



Rumors of our Demise...

**Have Been Greatly Exaggerated!**

Available at [SupplyHouse.com](http://SupplyHouse.com)



RED POP-UP INDICATOR TAB WHEN ACTIVATED



NO Electricity



NO Batteries



NO Wireless Signals



NO Maintenance



NO Worries

**AQUAGUARD**  
The Original Creators of the **wags™**  
SINCE 2002 MADE IN USA

"A WATER HEATERS BEST FRIEND"

**WAGSVALVE.COM**

## DS-AIPC-2000 CUTTER™

Adjustable Internal Pipe Cutter

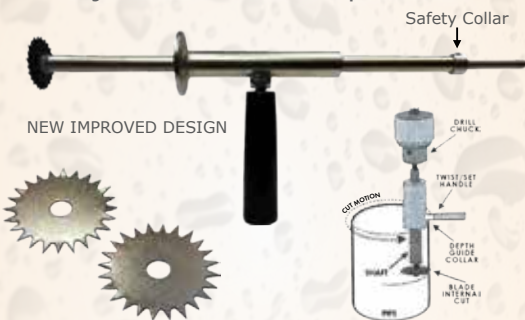

### NEW Internal Pipe Cutter Features

- Cuts pipe sizes 1½" thru 6"
- Adjustable cutting depth 1" to 6"
- Safety Collar prevents blade and shaft from falling down the pipe
- Ideal for tight spaces
- For cutting pipes against walls and below Concrete surfaces
- Handle gives stability & control to cutter

## PUSH & SHUV™

The Gasketed Adjustable Metal Ring Flush Type Closet Flange



- Fits inside 4" C.I., PVC, ABS & Lead pipe
- Gasket lube will make installation easier
- Fasten Flange to the floor with screws

**ds** DALLAS SPECIALTY & MFG CO.

[DallasSpecialty.com](http://DallasSpecialty.com) ■ 1-800-222-5644

1161 Ruggle St., Grand Prairie, TX 75050

## MyTana LLC

866-735-7684 • www.mytana.com

Ad on page 61

## Pulsar 2000, Inc.

214-388-8838 • www.pulsar2000.com

Ad on page 21

## Ratech Electronics, Ltd.

800-461-9200 • www.ratech-electronics.com

## Superior Signal Company LLC

732-251-0800 • www.SuperiorSignal.com/PLBG

Ad on page 73

## TROJAN WORLDWIDE INC.

800-392-4902 • www.trojanworldwide.com

## Western Drain Supply

714-632-0447 • www.westerndrain.com

## LOCATORS - SMOKE/DYE

### Central Oklahoma Winnelson

888-947-8761 • www.centralwinnelson.com

Ad on page 49

### Cherne Industries

800-843-7584 • www.cherneind.com

### EPL Solutions, Inc.

714-453-9769 • www.epls-usa.com

### Lansas Mfg. by Vanderlans & Sons Inc.

800-452-4902 • www.lansas.com



### Superior Signal Company LLC

732-251-0800 • www.SuperiorSignal.com/PLBG

Ad on page 73

## MONITORING EQUIPMENT

### SJE Rhombus

888-342-5753 • www.sjerhombus.com

## NOZZLES - HIGH PRESSURE

### Allan J. Coleman Co.

773-728-2400 • www.allanjcoleman.com

Ad on page 11



### Easy-Kleen Pressure Systems Ltd.

800-315-5533 • www.easycleen.com

Ad on page 67

### EPL Solutions, Inc.

714-453-9769 • www.epls-usa.com

## General Pump

888-474-5487 • www.generalpump.com

## Gorlitz Sewer & Drain, Inc.

877-446-7548 • www.gorlitz.com

## Hammelmann

800-783-4935 • www.hammelmann.com

## HotJet USA

800-624-8186 • www.hotjetusa.com

Ad on page 3, 73

## Hydra-Flex, Inc.

952-808-3640 • www.hydraflexinc.com

## J.M. McKinney Co.

800-821-7275

## JETTERS NORTHWEST

877-901-1936 • www.jettersonorthwest.com

## Milwaukee Rubber Products, Inc.

800-325-3730 • www.milwaukeerubber.com

## Mongoose Jetters by Sewer Equipment

877-735-4640 • www.sewerequipment.com/mongoose-jetters

Ad on page 39

## MyTana LLC

866-735-7684 • www.mytana.com

Ad on page 61



## Shamrock Nozzles By Triton HydroTools

800-633-7696 • www.shamrocktools.com



## SPARTAN TOOL

### Spartan Tool LLC

800-435-3866 • www.spartantool.com

Ad on page 2

### Suttner America Company

800-831-0660 • www.suttner.com

### TROJAN WORLDWIDE INC.

800-392-4902 • www.trojanworldwide.com



## USB-USA

### USB-USA

844-285-5770 • www.USB-USA.com

### Victor Manufacturing

815-672-3171 • www.victor.com

### Western Drain Supply

714-632-0447 • www.westerndrain.com

## ODOR CONTROL PRODUCTS/EQUIPMENT

### Arcan Enterprises

888-352-7226 • www.arcan.com

Ad on page 73

### Corro-Protec

877-466-6660 • www.corroprotec.com/product/water-heater-anode-rod

### Superior Signal Company LLC

732-251-0800 • www.SuperiorSignal.com/PLBG

Ad on page 73

## ONSITE SEPTIC SYSTEMS

### Crane Pumps & Systems

937-773-2442 • www.cranepumps.com

Ad on page 23

### Norweco, Inc.

800-667-9326 • www.norweco.com

### Zoeller Company

502-778-2731 • www.zoellerpumps.com

## PIPE - COPPER

### Central Oklahoma Winnelson

888-947-8761 • www.centralwinnelson.com

Ad on page 49

### Precision Plumbing Products

503-256-4010 • www.ppcinc.net

## PIPE - PEX

### Legend Valve

800-752-2082 • www.legendvalve.com

Ad on page 17

### REHAU Construction

800-247-9445 • www.na.rehau.com

## PIPE - POLYETHYLENE

### Asahi/America, Inc.

800-343-3618 • www.asahi-america.com

### Legend Valve

800-752-2082 • www.legendvalve.com

Ad on page 17

## PIPE - SUPPORTS

### Legend Valve

800-752-2082 • www.legendvalve.com

Ad on page 17

### Oatey Co.

800-321-9532 • www.oatey.com

Ad on page 45



**Ashland**  
P U M P

Sold to the For the By the  
**PROFESSIONAL**  
*Make the Professional Choice*

1899 Cottage St. □ Ashland, OH 44805 □ 855 281-6830 □ ashlandpump.com



Visit our YouTube channel to see actual videos

vCam-6 HD  
Inspection System

vCamMX-2\* Mini  
Inspection System

vCamDrain System

**vCam Inspection Cameras**  
**the clear choice for video inspection**

Call us for a no-obligation on-site demonstration! ☎ **1-800-446-3392**



+1-408-734-3880 SalesUSA@vxmt.com www.vivax-metrotech.com

Vivax-Metrotech Corporation

3251 Olcott Street, Santa Clara, CA 95054, USA

## PIPE BURSTING



**HammerHead Trenchless**  
800-331-6653 • [www.hammerheadtrenchless.com](http://www.hammerheadtrenchless.com)  
Ad on page 33

**Pow-r Mole Trenchless Solutions**  
800-344-6653 • [www.powrmole.com](http://www.powrmole.com)

**Roddie Inc**  
888-406-3821 • [www.roddieunderground.com](http://www.roddieunderground.com)  
Ad on page 5

**Source ONE Environmental**  
877-450-3701 • [www.s1eonline.com](http://www.s1eonline.com)

**TRIC Tools, Inc.**  
888-883-8742 • [www.trictools.com](http://www.trictools.com)

## PIPE CUTTERS

**Legend Valve**  
800-752-2082 • [www.legendvalve.com](http://www.legendvalve.com)  
Ad on page 17

## PIPE FUSION

**Asahi/America, Inc.**  
800-343-3618 • [www.asahi-america.com](http://www.asahi-america.com)

**Legend Valve**  
800-752-2082 • [www.legendvalve.com](http://www.legendvalve.com)  
Ad on page 17

**Oatey Co.**  
800-321-9532 • [www.oatey.com](http://www.oatey.com)  
Ad on page 45

## PIPE PARTS - FITTINGS & COMPONENTS

**A.Y. McDonald Mfg. Co.**  
800-292-2737 • [www.aymcdonald.com](http://www.aymcdonald.com)

**Arrowhead Brass**  
800-332-4267 • [www.arrowheadbrass.com](http://www.arrowheadbrass.com)

**Asahi/America, Inc.**  
800-343-3618 • [www.asahi-america.com](http://www.asahi-america.com)

**Legend Valve**  
800-752-2082 • [www.legendvalve.com](http://www.legendvalve.com)  
Ad on page 17

**PRIER Products**  
800-362-9055 • [www.prier.com](http://www.prier.com)  
Ad on page 25

**Vista Water Group**  
419-565-5702 • [www.vistawatergroup.com](http://www.vistawatergroup.com)

## PIPE PLUGS

**Cherne Industries**  
800-843-7584 • [www.cherneind.com](http://www.cherneind.com)

**Lansas Mfg. by Vanderlans & Sons Inc.**  
800-452-4902 • [www.lansas.com](http://www.lansas.com)

**Legend Valve**  
800-752-2082 • [www.legendvalve.com](http://www.legendvalve.com)  
Ad on page 17

**Superior Signal Company LLC**  
732-251-0800 • [www.SuperiorSignal.com/PLBG](http://www.SuperiorSignal.com/PLBG)  
Ad on page 73

## PIPE THAWING

**Allan J. Coleman Co.**  
773-728-2400 • [www.allanjcoleman.com](http://www.allanjcoleman.com)  
Ad on page 11

**Arctic Blaster, Inc.**  
403-636-1488 • [www.arcticblaster.com](http://www.arcticblaster.com)

**Central Oklahoma Winnelson**  
888-947-8761 • [www.centralwinnelson.com](http://www.centralwinnelson.com)  
Ad on page 49

**Easy-Kleen Pressure Systems Ltd.**  
800-315-5533 • [www.easykleen.com](http://www.easykleen.com)  
Ad on page 67

**General Pipe Cleaners, div. of General Wire Spring**  
800-245-6200 • [www.drainbrain.com](http://www.drainbrain.com)  
Ad on page 76

**Suttner America Company**  
800-831-0660 • [www.suttner.com](http://www.suttner.com)

## PIPE THREADERS

**Allan J. Coleman Co.**  
773-728-2400 • [www.allanjcoleman.com](http://www.allanjcoleman.com)  
Ad on page 11

## PIPELINE REHABILITATION/ LINING

**ACME TRENCHLESS**  
**ACME Trenchless**  
920-376-4222 • [www.acmetrenchless.com](http://www.acmetrenchless.com)  
Ad on page 67

**APS**  
— AMERICAN —  
PIPELINING SUPPLIES  
American Pipelining Supplies  
888-258-9359 • [www.americanpipeliningsupplies.com](http://www.americanpipeliningsupplies.com)

**Blackhawk Tech**  
630-326-9061 • [www.blackhawktechsupply.com](http://www.blackhawktechsupply.com)

**CPI Products / Cavallero Plastics**  
413-443-0925 • [www.cplproducts.com](http://www.cplproducts.com)

**Cua Claws**  
**Cua Claws for Resurfacing Camera Wheels**  
714-697-8697 • [www.cuac claws.com](http://www.cuac claws.com)  
Ad on page 73

**CUES**  
CUES, Inc.  
800-327-7791 • [www.cuesinc.com](http://www.cuesinc.com)

**Easy-Kleen Pressure Systems Ltd.**  
800-315-5533 • [www.easykleen.com](http://www.easykleen.com)  
Ad on page 67

**THE SHOOTER**  
EMAGINEERED SOLUTIONS INC  
541-504-0416 • [www.theshootercipp.com](http://www.theshootercipp.com)



**HammerHead Trenchless**  
800-331-6653 • [www.hammerheadtrenchless.com](http://www.hammerheadtrenchless.com)  
Ad on page 33



**Infrastructure Repair Systems, Inc.**  
727-327-4216 • [www.iri.net](http://www.iri.net)

**IPP Solutions, LLC**  
970-444-5655 • [www.ippsolutions.com](http://www.ippsolutions.com)  
Ad on page 59

**Lansas Mfg. by Vanderlans & Sons Inc.**  
800-452-4902 • [www.lansas.com](http://www.lansas.com)



**MaxLiner**

877-426-5948 • www.maxlinerusa.com

Ad on page 75

**NuFlow Technologies**

866-430-2134 • www.nuflow.com

Ad on page 37

**Picote Solutions**

864-940-0088 • www.picotegroup.com

Ad on page 69

**Pipeline Renewal Technologies**

866-936-8476 • www.pipeliner.com

Ad on page 65

**Pow-r Mole Trenchless Solutions**

800-344-6653 • www.powrmole.com

**Ratech Electronics, Ltd.**

800-461-9200 • www.ratech-electronics.com

**RauschUSA**

877-728-7241 • www.rauschusa.com

Ad on page 55

**Source ONE Environmental**

877-450-3701 • www.s1eonline.com

**SPARTAN TOOL****Spartan Tool LLC**

800-435-3866 • www.spartantool.com

Ad on page 2

**TRIC Tools, Inc.**

888-883-8742 • www.trictools.com

**TRY TEK Machine Works, Inc.**

717-428-1477 • www.trytek.com

**Warrior Trenchless Solutions**

716-601-7760 • www.thermoformliner.com

**PLUMBING PRODUCTS****A.Y. McDonald Mfg. Co.**

800-292-2737 • www.aymcdonald.com

**AQUAGUARD LLC**

844-438-9247 • www.wagsvalve.com

Ad on page 51

**AquaMotion, Inc.**

401-785-3000 • www.aquamotionhvac.com

**Arcan Enterprises**

888-352-7226 • www.arcan.com

Ad on page 73

**Arrowhead Brass**

800-332-4267 • www.arrowheadbrass.com

**Central Oklahoma Winnelson**

888-947-8761 • www.centralwinnelson.com

Ad on page 49

**Corro-Protec**877-466-6660 • www.corroprotec.com/  
product/water-heater-anode-rod**Crane Pumps & Systems**

937-773-2442 • www.cranepumps.com

Ad on page 23

**Dallas Specialty & Mfg. Co.**

800-222-5644 • www.dallaspecialty.com

Ad on page 51

# rausch USA

**minCord 5**

Inspection system



## Compact Light weight Flexible

- 5" anti-glare display
- Color camera head 13 mm
- Pipe diameter 0.5" - 3"
- Bend capability from 1"
- 50 ft Flexible Push cable

717-709-1005 • www.rauschusa.com

1886 Opportunity Ave. Chambersburg PA 17201

## Heat-flo

508-278-2400 • [www.heatflo.com](http://www.heatflo.com)

Ad on page 57

## Hydra-Flex, Inc.

952-808-3640 • [www.hydraflexinc.com](http://www.hydraflexinc.com)

## Legend Valve

800-752-2082 • [www.legendvalve.com](http://www.legendvalve.com)

Ad on page 17

## Oatey Co.

800-321-9532 • [www.oatey.com](http://www.oatey.com)

Ad on page 45

## Precision Plumbing Products

503-256-4010 • [www.ppcinc.net](http://www.ppcinc.net)

## PRIER Products

800-362-9055 • [www.prier.com](http://www.prier.com)

Ad on page 25

## **rausch** USA

### RauschUSA

877-728-7241 • [www.rauschusa.com](http://www.rauschusa.com)

Ad on page 55

## REHAU Construction

800-247-9445 • [www.na.rehau.com](http://www.na.rehau.com)

## SalesMaker Carts

800-821-4140 • [www.saleismakercarts.com](http://www.saleismakercarts.com)

Ad on page 65

## Saniflo SFA Inc.

800-571-8191 • [www.saniflo.com](http://www.saniflo.com)

## Source ONE Environmental

877-450-3701 • [www.s1eonline.com](http://www.s1eonline.com)

## SuppliesDepot.com

800-359-1334 • [www.suppliesdepot.com](http://www.suppliesdepot.com)

Ad on page 7

## U.S. Boiler Company, Inc.

888-432-8887 • [www.usboiler.net](http://www.usboiler.net)

## Vista Water Group

419-565-5702 • [www.vistawatergroup.com](http://www.vistawatergroup.com)

## Western Drain Supply

714-632-0447 • [www.westernrain.com](http://www.westernrain.com)

## PRESSURE WASHERS AND SPRAYERS



### Cam Spray

800-648-5011 • [www.camspray.com](http://www.camspray.com)

Ad on page 15

## Easy-Kleen Pressure Systems Ltd.

800-315-5533 • [www.easycleen.com](http://www.easycleen.com)

Ad on page 67

## THE SHOOTER™

### EMAGINEERED SOLUTIONS INC

541-504-0416 • [www.theshooterripp.com](http://www.theshooterripp.com)

### HotJet USA

800-624-8186 • [www.hotjetusa.com](http://www.hotjetusa.com)

Ad on page 3, 73

### Hydra-Flex, Inc.

952-808-3640 • [www.hydraflexinc.com](http://www.hydraflexinc.com)

### JETTERS NORTHWEST

877-901-1936 • [www.jettersonorthwest.com](http://www.jettersonorthwest.com)

### Root Rat

800-288-7873 • [www.rootrat.net](http://www.rootrat.net)

Ad on page 73

## PUMP CONTROL PANELS

### Liberty Pumps

800-543-2550 • [www.LibertyPumps.com](http://www.LibertyPumps.com)

Ad on page 41

### Little Giant

800-701-7894 • [www.LittleGiant.com](http://www.LittleGiant.com)

Ad on page 35

### SJE Rhombus

888-342-5753 • [www.sjerrhombus.com](http://www.sjerrhombus.com)

### Zoeller Company

502-778-2731 • [www.zoellerpumps.com](http://www.zoellerpumps.com)

## PUMP PARTS/COMPONENTS

### Ashland Pump

855-281-6830 • [www.ashlandpump.com](http://www.ashlandpump.com)

Ad on page 53

### Crane Pumps & Systems

937-773-2442 • [www.cranepumps.com](http://www.cranepumps.com)

Ad on page 23

### General Pump

888-474-5487 • [www.generalpump.com](http://www.generalpump.com)

### Mongoose Jetters by Sewer Equipment

877-735-4640 • [www.sewerequipment.com/mongoose-jetters](http://www.sewerequipment.com/mongoose-jetters)

Ad on page 39

### Root Rat

800-288-7873 • [www.rootrat.net](http://www.rootrat.net)

Ad on page 73

### SJE Rhombus

888-342-5753 • [www.sjerrhombus.com](http://www.sjerrhombus.com)

## PUMP REPAIR/SERVICES

### Root Rat

800-288-7873 • [www.rootrat.net](http://www.rootrat.net)

Ad on page 73

## PUMPS - AERATION

### Norweco, Inc.

800-667-9326 • [www.norweco.com](http://www.norweco.com)

## PUMPS - BOILER

### AquaMotion, Inc.

401-785-3000 • [www.aquamotionhvac.com](http://www.aquamotionhvac.com)

## PUMPS - CENTRIFUGAL

### AquaMotion, Inc.

401-785-3000 • [www.aquamotionhvac.com](http://www.aquamotionhvac.com)

### Crane Pumps & Systems

937-773-2442 • [www.cranepumps.com](http://www.cranepumps.com)

Ad on page 23

### Little Giant

800-701-7894 • [www.LittleGiant.com](http://www.LittleGiant.com)

Ad on page 35

## PUMPS - CIRCULATING

### AquaMotion, Inc.

401-785-3000 • [www.aquamotionhvac.com](http://www.aquamotionhvac.com)

### Little Giant

800-701-7894 • [www.LittleGiant.com](http://www.LittleGiant.com)

Ad on page 35

### SuppliesDepot.com

800-359-1334 • [www.suppliesdepot.com](http://www.suppliesdepot.com)

Ad on page 7

## PUMPS - CONDENSATE

### Ashland Pump

855-281-6830 • [www.ashlandpump.com](http://www.ashlandpump.com)

Ad on page 53

### Liberty Pumps

800-543-2550 • [www.LibertyPumps.com](http://www.LibertyPumps.com)

Ad on page 41

## Little GIANT®

### Little Giant

800-701-7894 • [www.LittleGiant.com](http://www.LittleGiant.com)

Ad on page 35

### Saniflo SFA Inc.

800-571-8191 • [www.saniflo.com](http://www.saniflo.com)

### SuppliesDepot.com

800-359-1334 • [www.suppliesdepot.com](http://www.suppliesdepot.com)

Ad on page 7

## PUMPS - CONSTANT PRESSURE

### A.Y. McDonald Mfg. Co.

800-292-2737 • [www.aymcdonald.com](http://www.aymcdonald.com)

### Little Giant

800-701-7894 • [www.LittleGiant.com](http://www.LittleGiant.com)

Ad on page 35

## PUMPS - EFFLUENT/ SEWAGE/SUMP

A.Y. McDonald Mfg. Co.  
800-292-2737 • www.aymcdonald.com



**Ashland Pump**  
855-281-6830 • www.ashlandpump.com  
Ad on page 53

**Central Oklahoma Winnelson**  
888-947-8761 • www.centralwinnelson.com  
Ad on page 49

**Crane Pumps & Systems**  
937-773-2442 • www.cranepumps.com  
Ad on page 23

**Liberty Pumps**  
800-543-2550 • www.LibertyPumps.com  
Ad on page 41

## Little GIANT

**Little Giant**  
800-701-7894 • www.LittleGiant.com  
Ad on page 35

**Saniflo SFA Inc.**  
800-571-8191 • www.saniflo.com

**Zoeller Company**  
502-778-2731 • www.zoellerpumps.com

## PUMPS - GRINDER



**Ashland Pump**  
855-281-6830 • www.ashlandpump.com  
Ad on page 53

**Crane Pumps & Systems**  
937-773-2442 • www.cranepumps.com  
Ad on page 23



**Liberty Pumps**  
800-543-2550 • www.LibertyPumps.com  
Ad on page 41

## Little GIANT

**Little Giant**  
800-701-7894 • www.LittleGiant.com  
Ad on page 35

**Saniflo SFA Inc.**  
800-571-8191 • www.saniflo.com

**SuppliesDepot.com**  
800-359-1334 • www.suppliesdepot.com  
Ad on page 7

**Zoeller Company**  
502-778-2731 • www.zoellerpumps.com

## PUMPS - HIGH PRESSURE WATER

**Easy-Kleen Pressure Systems Ltd.**  
800-315-5533 • www.easykleen.com  
Ad on page 67

**General Pump**  
888-474-5487 • www.generalpump.com

**Hammelmann**  
800-783-4935 • www.hammelmann.com

**HotJet USA**  
800-624-8186 • www.hotjetusa.com  
Ad on page 3, 73

**JETTERS NORTHWEST**  
877-901-1936 • www.jettersnorthwest.com

**Little Giant**  
800-701-7894 • www.LittleGiant.com  
Ad on page 35



# Heat-flo

**HIGH QUALITY PRODUCT +  
OUTSTANDING PERFORMANCE =  
CUSTOMER SATISFACTION**

Now That's What We Call

**RAISING THE STANDARD**



**HEAT-FLO, INC.**  
15 MEGAN CT., P.O. BOX 612, UXBRIDGE,  
MA 01569, USA

PHONE: (508) 278-2400 | FAX: (508) 278-2466  
E-MAIL: SALES@HEAT-FLO.COM  
WWW.HEAT-FLO.COM



ALL HEAT-FLO  
PRODUCTS ARE PROUDLY  
ENGINEERED & BUILT  
IN THE USA



## Mongoose Jetters by Sewer Equipment

877-735-4640 • [www.sewerequipment.com/mongoose-jettors](http://www.sewerequipment.com/mongoose-jettors)

Ad on page 39

## Root Rat

800-288-7873 • [www.rootrat.net](http://www.rootrat.net)

Ad on page 73

## PUMPS - HVAC

### Little Giant

800-701-7894 • [www.LittleGiant.com](http://www.LittleGiant.com)

Ad on page 35

## PUMPS - PRESSURE BOOSTING

### A.Y. McDonald Mfg. Co.

800-292-2737 • [www.aymcdonald.com](http://www.aymcdonald.com)

### AquaMotion, Inc.

401-785-3000 • [www.aquamotionhvac.com](http://www.aquamotionhvac.com)

### Little Giant

800-701-7894 • [www.LittleGiant.com](http://www.LittleGiant.com)

Ad on page 35

### SuppliesDepot.com

800-359-1334 • [www.suppliesdepot.com](http://www.suppliesdepot.com)

Ad on page 7

### Zoeller Company

502-778-2731 • [www.zoellerpumps.com](http://www.zoellerpumps.com)

## PUMPS - RECIRCULATION

### AquaMotion, Inc.

401-785-3000 • [www.aquamotionhvac.com](http://www.aquamotionhvac.com)

### Little Giant

800-701-7894 • [www.LittleGiant.com](http://www.LittleGiant.com)

Ad on page 35

## PUMPS - SUBMERSIBLE

### A.Y. McDonald Mfg. Co.

800-292-2737 • [www.aymcdonald.com](http://www.aymcdonald.com)

### Ashland Pump

855-281-6830 • [www.ashlandpump.com](http://www.ashlandpump.com)

Ad on page 53

### Crane Pumps & Systems

937-773-2442 • [www.cranepumps.com](http://www.cranepumps.com)

Ad on page 23

### Liberty Pumps

800-543-2550 • [www.LibertyPumps.com](http://www.LibertyPumps.com)

Ad on page 41

### Little Giant

800-701-7894 • [www.LittleGiant.com](http://www.LittleGiant.com)

Ad on page 35

### SuppliesDepot.com

800-359-1334 • [www.suppliesdepot.com](http://www.suppliesdepot.com)

Ad on page 7

## Zoeller Company

502-778-2731 • [www.zoellerpumps.com](http://www.zoellerpumps.com)

## PUMPS - UTILITY



### Ashland Pump

855-281-6830 • [www.ashlandpump.com](http://www.ashlandpump.com)

Ad on page 53

## Little GIANT

### Little Giant

800-701-7894 • [www.LittleGiant.com](http://www.LittleGiant.com)

Ad on page 35

### Saniflo SFA Inc.

800-571-8191 • [www.saniflo.com](http://www.saniflo.com)

### Zoeller Company

502-778-2731 • [www.zoellerpumps.com](http://www.zoellerpumps.com)

## PUMPS - WATER

### AquaMotion, Inc.

401-785-3000 • [www.aquamotionhvac.com](http://www.aquamotionhvac.com)

### Ashland Pump

855-281-6830 • [www.ashlandpump.com](http://www.ashlandpump.com)

Ad on page 53

### General Pump

888-474-5487 • [www.generalpump.com](http://www.generalpump.com)

### Liberty Pumps

800-543-2550 • [www.LibertyPumps.com](http://www.LibertyPumps.com)

Ad on page 41

### Little Giant

800-701-7894 • [www.LittleGiant.com](http://www.LittleGiant.com)

Ad on page 35

## RADIANT HEATING

### Heat-flo

508-278-2400 • [www.heat-flo.com](http://www.heat-flo.com)

Ad on page 57

### REHAU Construction

800-247-9445 • [www.na.rehau.com](http://www.na.rehau.com)

### U.S. Boiler Company, Inc.

888-432-8887 • [www.usboiler.net](http://www.usboiler.net)

## REINSTATEMENT CUTTERS

### Alpine Equipment Funding, Inc.

800-640-8660 • [www.alpineequipmentfunding.com](http://www.alpineequipmentfunding.com)

### American Pipelining Supplies

888-258-9359 • [www.americanpipeliningsupplies.com](http://www.americanpipeliningsupplies.com)

### Blackhawk Tech

630-326-9061 • [www.blackhawktechsupply.com](http://www.blackhawktechsupply.com)



### CUES, Inc.

800-327-7791 • [www.cuesinc.com](http://www.cuesinc.com)

### EPL Solutions, Inc.

714-453-9769 • [www.epls-usa.com](http://www.epls-usa.com)



### Picote Solutions

864-940-0088 • [www.picotegroup.com](http://www.picotegroup.com)

Ad on page 69

### Pipeline Renewal Technologies

866-936-8476 • [www.pipeline-rt.com](http://www.pipeline-rt.com)

Ad on page 65

### Source ONE Environmental

877-450-3701 • [www.s1eonline.com](http://www.s1eonline.com)

### TRY TEK Machine Works, Inc.

717-428-1477 • [www.trytek.com](http://www.trytek.com)

## RENTAL EQUIPMENT

### Hammelmann

800-783-4935 • [www.hammelmann.com](http://www.hammelmann.com)

### Lansas Mfg. by Vanderlans & Sons Inc.

800-452-4902 • [www.lansas.com](http://www.lansas.com)

### Mongoose Jetters by Sewer Equipment

877-735-4640 • [www.sewerequipment.com/mongoose-jettors](http://www.sewerequipment.com/mongoose-jettors)

Ad on page 39

### Pipeline Renewal Technologies

866-936-8476 • [www.pipeline-rt.com](http://www.pipeline-rt.com)

Ad on page 65

## REPAIR/REBUILDING EQUIPMENT

### EPL Solutions, Inc.

714-453-9769 • [www.epls-usa.com](http://www.epls-usa.com)

### J.M. McKinney Co.

800-821-7275

### JETTERS NORTHWEST

877-901-1936 • [www.jettersonorthwest.com](http://www.jettersonorthwest.com)

### Mongoose Jetters by Sewer Equipment

877-735-4640 • [www.sewerequipment.com/mongoose-jettors](http://www.sewerequipment.com/mongoose-jettors)

Ad on page 39

### TROJAN WORLDWIDE INC.

800-392-4902 • [www.trojanworldwide.com](http://www.trojanworldwide.com)

### Western Drain Supply

714-632-0447 • [www.westerndrain.com](http://www.westerndrain.com)

## RODDING MACHINES

### General Pipe Cleaners, div. of General Wire Spring

800-245-6200 • [www.drainbrain.com](http://www.drainbrain.com)

Ad on page 76



**Picote Solutions**  
864-940-0088 • www.picotegroup.com  
Ad on page 69



**SPARTAN TOOL**  
**Spartan Tool LLC**  
800-435-3866 • www.spartantool.com  
Ad on page 2

## ROOT CONTROL - CHEMICAL

**Duracable Manufacturing Co.**  
800-247-4081 • www.duracable.com  
Ad on page 43

**J.M. McKinney Co.**  
800-821-7275

**Oatey Co.**  
800-321-9532 • www.oatey.com  
Ad on page 45



**RootX**  
800-844-4974 • www.rootx.com

## ROOT CONTROL - MECHANICAL



**Arthur Products Co.**  
800-322-0510 • www.arthurproducts.com

**Duracable Manufacturing Co.**  
800-247-4081 • www.duracable.com  
Ad on page 43

**EPL Solutions, Inc.**  
714-453-9769 • www.epls-usa.com

**Gorlitz Sewer & Drain, Inc.**  
877-446-7548 • www.gorlitz.com

**Hydra-Flex, Inc.**  
952-808-3640 • www.hydrflexinc.com

**JETTERS NORTHWEST**  
877-901-1936 • www.jettersnorthwest.com



**Picote Solutions**  
864-940-0088 • www.picotegroup.com  
Ad on page 69

**Root Rat**  
800-288-7873 • www.rootrat.net  
Ad on page 73



**Shamrock Nozzles By Triton HydroTools**  
800-633-7696 • www.shamrocktools.com



**USB-USA**  
844-285-5770 • www.USB-USA.com

# We are redefining pipe rehabilitation

SIPP (Sprayed In Place Pipelining) casting system presents a cost-effective solution compared to European products. Through direct application of the resin, no need to use liners - No need for any reinstatements. Can be used through existing access points in the structure.

## We Offer the Best Training and Support in the Business

- 100% polyurea [No foaming]
- Chemical resistant
- ASTM tested, 60 sec cure time (compared to competitors 10 min. to 2 hrs.)
- 10 year warranty
- Long shelf life
- Made in USA
- High quality standard
- ISO 9001
- Easy to apply

Small Sprayhead  
1½" - 6"  
Pipe diameter



Large Sprayhead  
6" - 20"  
Pipe diameter



Not ready to buy?  
Rentals Available!



Equipment and resin made in USA,  
ready to ship today - no lead time.

Leading Edge In Sprayed In Place Pipeline Technology

— Financing Available —

+1.970.444.5655  
www.ipsolutions.com

**ipp**  
Solutions, LLC

## SAFETY EQUIPMENT/ PERSONAL PROTECTION

Milwaukee Rubber Products, Inc.  
800-325-3730 • [www.milwaukeeerubber.com](http://www.milwaukeeerubber.com)

SpitzLift Manufacturing  
619-713-5061 • [www.spitzlift.com](http://www.spitzlift.com)

## SEPTIC DRAINFIELD RESTORATION

CPI Products / Cavallero Plastics  
413-443-0925 • [www.cplproducts.com](http://www.cplproducts.com)

Superior Signal Company LLC  
732-251-0800 • [www.SuperiorSignal.com/PLBG](http://www.SuperiorSignal.com/PLBG)  
Ad on page 73

## SEPTIC SYSTEM COMPONENTS

Arcan Enterprises  
888-352-7226 • [www.arcan.com](http://www.arcan.com)  
Ad on page 73

CPI Products / Cavallero Plastics  
413-443-0925 • [www.cplproducts.com](http://www.cplproducts.com)

SJE Rhombus  
888-342-5753 • [www.sjerhombus.com](http://www.sjerhombus.com)

## SEPTIC TANK POLY

Norweco, Inc.  
800-667-9326 • [www.norweco.com](http://www.norweco.com)

## SERVICE VANS

Alpine Equipment Funding, Inc.  
800-640-8660 • [www.alpineequipmentfunding.com](http://www.alpineequipmentfunding.com)

## SHOWER PAN LINERS



Dallas Specialty & Mfg. Co.  
800-222-5644 • [www.dallaspecialty.com](http://www.dallaspecialty.com)  
Ad on page 51

## SHOWERS

Dallas Specialty & Mfg. Co.  
800-222-5644 • [www.dallaspecialty.com](http://www.dallaspecialty.com)  
Ad on page 51

**DURAVIT**

Duravit USA, Inc.  
770-931-3575 • [www.pro.duravit.us/](http://www.pro.duravit.us/)  
Ad on page 9

## SINKS

**DURAVIT**

Duravit USA, Inc.  
770-931-3575 • [www.pro.duravit.us/](http://www.pro.duravit.us/)  
Ad on page 9

## SIPP EQUIPMENT & MATERIALS

EPL Solutions, Inc.  
714-453-9769 • [www.epls-usa.com](http://www.epls-usa.com)

## SOFTWARE - BUSINESS

FastEST, Inc.  
800-828-7108 • [www.fastest-inc.com](http://www.fastest-inc.com)  
Ad on page 69

## SOFTWARE - INSPECTION/ MAPPING



CUES, Inc.  
800-327-7791 • [www.cuesinc.com](http://www.cuesinc.com)

Ratech Electronics, Ltd.  
800-461-9200 • [www.ratech-electronics.com](http://www.ratech-electronics.com)

**VIVAX**  
**METROTECH**

Vivax-Metrotech Corp.  
800-446-3392 • [www.vxmt.com](http://www.vxmt.com)  
Ad on page 53

## STAINLESS MATERIALS

Hydra-Flex, Inc.  
952-808-3640 • [www.hydraflexinc.com](http://www.hydraflexinc.com)

## TANKS - STORAGE

Bradford White Water Heaters  
215-641-9400 • [www.bradfordwhite.com](http://www.bradfordwhite.com)  
Ad on page 47

Corro-Protec  
877-466-6660 • [www.corroprotec.com/product/water-heater-anode-rod](http://www.corroprotec.com/product/water-heater-anode-rod)

Heat-flo  
508-278-2400 • [www.heat-flo.com](http://www.heat-flo.com)  
Ad on page 57

## TANKS - WASTEWATER

Crane Pumps & Systems  
937-773-2442 • [www.cranepumps.com](http://www.cranepumps.com)  
Ad on page 23

Norweco, Inc.  
800-667-9326 • [www.norweco.com](http://www.norweco.com)

## THERMOSTATS

Legend Valve  
800-752-2082 • [www.legendvalve.com](http://www.legendvalve.com)  
Ad on page 17

## TOILET PARTS AND ACCESSORIES

Dallas Specialty & Mfg. Co.  
800-222-5644 • [www.dallaspecialty.com](http://www.dallaspecialty.com)  
Ad on page 51

**DURAVIT**

Duravit USA, Inc.  
770-931-3575 • [www.pro.duravit.us/](http://www.pro.duravit.us/)  
Ad on page 9

Oatey Co.  
800-321-9532 • [www.oatey.com](http://www.oatey.com)  
Ad on page 45

## TOILETS



**Duravit USA, Inc.**

770-931-3575 • [www.pro.duravit.us/](http://www.pro.duravit.us/)

Ad on page 9

**Saniflo SFA Inc.**

800-571-8191 • [www.saniflo.com](http://www.saniflo.com)

## TOOLS - POWER

**ACME Trenchless**

920-376-4222 • [www.acmetrenchless.com](http://www.acmetrenchless.com)

Ad on page 67

**Qescorp d/b/a DiscountSawBlade.com**

888-641-9798 • [www.discountssawblade.com](http://www.discountssawblade.com)

Ad on page 71

**Western Drain Supply**

714-632-0447 • [www.westerndrain.com](http://www.westerndrain.com)

## TRAILER PARTS AND ACCESSORIES

**Hydra-Flex, Inc.**

952-808-3640 • [www.hydraflexinc.com](http://www.hydraflexinc.com)

**Milwaukee Rubber Products, Inc.**

800-325-3730 • [www.milwaukeerubber.com](http://www.milwaukeerubber.com)

**Vactor Manufacturing**

815-672-3171 • [www.vactor.com](http://www.vactor.com)

## TRAILERS

**American Pipelining Supplies**

888-258-9359 • [www.americanpipeliningsupplies.com](http://www.americanpipeliningsupplies.com)

**Vactor Manufacturing**

815-672-3171 • [www.vactor.com](http://www.vactor.com)

## TRAPS

**Dallas Specialty & Mfg. Co.**

800-222-5644 • [www.dallasspecialty.com](http://www.dallasspecialty.com)

Ad on page 51

**Precision Plumbing Products**

503-256-4010 • [www.ppcinc.net](http://www.ppcinc.net)

## TRENCHLESS POINT/ SPOT REPAIR



**ACME Trenchless**

920-376-4222 • [www.acmetrenchless.com](http://www.acmetrenchless.com)

Ad on page 67

**Alpine Equipment Funding, Inc.**

800-640-8660 • [www.alpineequipmentfunding.com](http://www.alpineequipmentfunding.com)

**American Pipelining Supplies**

888-258-9359 • [www.americanpipeliningsupplies.com](http://www.americanpipeliningsupplies.com)

**Blackhawk Tech**

630-326-9061 • [www.blackhawktechsupply.com](http://www.blackhawktechsupply.com)



**CUES, Inc.**

800-327-7791 • [www.cuesinc.com](http://www.cuesinc.com)

**EPL Solutions, Inc.**

714-453-9769 • [www.epls-usa.com](http://www.epls-usa.com)

**FORMADRAIN**

888-337-6764 • <https://formadrain.com/>

Ad on page 31



**MS11-NG2  
Inspection System**

For 3"-6" lines  
Clear imagery  
Wireless streaming  
Long battery life

**MS11+ Combo Kit**  
Interchangeable mini camera  
head for 1½"-2" lines



## INSPECT & CLEAN

# RELIABLE PERFORMANCE.

Rugged cameras, jetters  
and cable machines that  
deliver high performance.

Service and support teams  
that give you the power  
to stay productive.



Financing available, visit [mytana.com/leasing-information](http://mytana.com/leasing-information)

[www.MyTana.com](http://www.MyTana.com) ■ (866) 735-7684

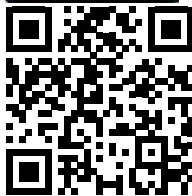

**HammerHead Trenchless**  
800-331-6653 • [www.hammerheadtrenchless.com](http://www.hammerheadtrenchless.com)  
Ad on page 33



**InfraStructure Repair Systems, Inc.**  
727-327-4216 • [www.irsj.net](http://www.irsj.net)

**NuFlow Technologies**  
866-430-2134 • [www.nuflow.com](http://www.nuflow.com)  
Ad on page 37



**Picote Solutions**  
864-940-0088 • [www.picotegroup.com](http://www.picotegroup.com)  
Ad on page 69

**Pipeline Renewal Technologies**  
866-936-8476 • [www.pipelinerf.com](http://www.pipelinerf.com)  
Ad on page 65

**Source ONE Environmental**  
877-450-3701 • [www.s1eonline.com](http://www.s1eonline.com)



**SPARTAN TOOL**  
**Spartan Tool LLC**  
800-435-3866 • [www.spartantool.com](http://www.spartantool.com)  
Ad on page 2

## TRUCK PARTS/ACCESSORIES

**Vactor Manufacturing**  
815-672-3171 • [www.vactor.com](http://www.vactor.com)

## TUBING

**Legend Valve**  
800-752-2082 • [www.legendvalve.com](http://www.legendvalve.com)  
Ad on page 17

**REHAU Construction**  
800-247-9445 • [www.na.rehau.com](http://www.na.rehau.com)

## UNIONS

**Legend Valve**  
800-752-2082 • [www.legendvalve.com](http://www.legendvalve.com)  
Ad on page 17

## UV CIPP

**MaxLiner**  
877-426-5948 • [www.maxlinerusa.com](http://www.maxlinerusa.com)  
Ad on page 75

## UV DISINFECTION EQUIPMENT

**Norweco, Inc.**  
800-667-9326 • [www.norweco.com](http://www.norweco.com)

## VALVE BOXES/COMPONENTS

**Asahi/America, Inc.**  
800-343-3618 • [www.asahi-america.com](http://www.asahi-america.com)

**Dallas Specialty & Mfg. Co.**  
800-222-5644 • [www.dallasspecialty.com](http://www.dallasspecialty.com)  
Ad on page 51

## VALVES - ACTUATORS/CONTROLS

**Arrowhead Brass**  
800-332-4267 • [www.arrowheadbrass.com](http://www.arrowheadbrass.com)

**Asahi/America, Inc.**  
800-343-3618 • [www.asahi-america.com](http://www.asahi-america.com)



**Duravit USA, Inc.**  
770-931-3575 • [www.pro.duravit.us/](http://www.pro.duravit.us/)  
Ad on page 9

**Legend Valve**  
800-752-2082 • [www.legendvalve.com](http://www.legendvalve.com)  
Ad on page 17

**Suttner America Company**  
800-831-0660 • [www.suttner.com](http://www.suttner.com)



**Viega LLC**  
800-976-9819 • [www.viega.us](http://www.viega.us)

## VALVES - AIR RELIEF

**Asahi/America, Inc.**  
800-343-3618 • [www.asahi-america.com](http://www.asahi-america.com)

**Legend Valve**  
800-752-2082 • [www.legendvalve.com](http://www.legendvalve.com)  
Ad on page 17

## VALVES - BACKFLOW PREVENTION/CHECK/FLOAT

**A.Y. McDonald Mfg. Co.**  
800-292-2737 • [www.aymcdonald.com](http://www.aymcdonald.com)

**AQUAGUARD LLC**  
844-438-9247 • [www.wagsvalve.com](http://www.wagsvalve.com)  
Ad on page 51

**Arrowhead Brass**  
800-332-4267 • [www.arrowheadbrass.com](http://www.arrowheadbrass.com)

**Asahi/America, Inc.**  
800-343-3618 • [www.asahi-america.com](http://www.asahi-america.com)

**Legend Valve**  
800-752-2082 • [www.legendvalve.com](http://www.legendvalve.com)  
Ad on page 17

**Liberty Pumps**  
800-543-2550 • [www.LibertyPumps.com](http://www.LibertyPumps.com)  
Ad on page 41

**Milwaukee Rubber Products, Inc.**  
800-325-3730 • [www.milwaukeerubber.com](http://www.milwaukeerubber.com)

**PRIER Products**  
800-362-9055 • [www.prier.com](http://www.prier.com)  
Ad on page 25

**Suttner America Company**  
800-831-0660 • [www.suttner.com](http://www.suttner.com)



**Viega LLC**  
800-976-9819 • [www.viega.us](http://www.viega.us)

**Vista Water Group**  
419-565-5702 • [www.vistawatergroup.com](http://www.vistawatergroup.com)



## VALVES - BALL

A.Y. McDonald Mfg. Co.  
800-292-2737 • www.aymcdonald.com

Arrowhead Brass  
800-332-4267 • www.arrowheadbrass.com

Asahi/America, Inc.  
800-343-3618 • www.asahi-america.com

General Pump  
888-474-5487 • www.generalpump.com

**Legend Valve**  
800-752-2082 • www.legendvalve.com  
Ad on page 17

**Liberty Pumps**  
800-543-2550 • www.LibertyPumps.com  
Ad on page 41

Milwaukee Rubber Products, Inc.  
800-325-3730 • www.milwaukeeerubber.com



Viega LLC  
800-976-9819 • www.viega.us

## VALVES - BUTTERFLY

Asahi/America, Inc.  
800-343-3618 • www.asahi-america.com

**Legend Valve**  
800-752-2082 • www.legendvalve.com  
Ad on page 17

## VALVES - PRESSURE REGULATING

A.Y. McDonald Mfg. Co.  
800-292-2737 • www.aymcdonald.com

General Pump  
888-474-5487 • www.generalpump.com

**Legend Valve**  
800-752-2082 • www.legendvalve.com  
Ad on page 17

Precision Plumbing Products  
503-256-4010 • www.ppcinc.net

Suttner America Company  
800-831-0660 • www.suttner.com

## VALVES - THERMOSTATIC

**Legend Valve**  
800-752-2082 • www.legendvalve.com  
Ad on page 17

Precision Plumbing Products  
503-256-4010 • www.ppcinc.net

## VALVES - WATER AND GAS

A.Y. McDonald Mfg. Co.  
800-292-2737 • www.aymcdonald.com



Arrowhead Brass  
800-332-4267 • www.arrowheadbrass.com

Asahi/America, Inc.  
800-343-3618 • www.asahi-america.com

**Legend Valve**  
800-752-2082 • www.legendvalve.com  
Ad on page 17

**PRIER Products**  
800-362-9055 • www.prier.com  
Ad on page 25



Viega LLC  
800-976-9819 • www.viega.us

## WATER CONDITIONERS

**Aqua-Rex LLC**  
877-640-2170 • www.aqua-rex.com  
Ad on page 27

Corro-Protec  
877-466-6660 • www.corroprotec.com/  
product/water-heater-anode-rod



**ENPRESS LLC**  
866-859-9274 • www.enpress.com  
Ad on page 22

**SuppliesDepot.com**  
800-359-1334 • www.suppliesdepot.com  
Ad on page 7

## WATER HEATER - ANODE ROD

Corro-Protec  
877-466-6660 • www.corroprotec.com/  
product/water-heater-anode-rod

## WATER TREATMENT

**Aqua-Rex LLC**  
877-640-2170 • www.aqua-rex.com  
Ad on page 27

Corro-Protec  
877-466-6660 • www.corroprotec.com/  
product/water-heater-anode-rod



## WATER/WASTEWATER REUSE SYSTEMS

Norweco, Inc.  
800-667-9326 • www.norweco.com

# Plumber

Remember,  
Plumber is free!

Subscribe today at:  
[www.plumbermag.com](http://www.plumbermag.com)

# Mastering the Craft

Tips to taking care of your daily-used tools so they last a long time for you and your team

By Cory Dellenbach

**A**s a plumber, your tools are not just instruments of your trade; they are the extensions of your expertise, your companions in the field and your lifeline when tackling challenging jobs.

From wrenches to pipe cutters, each tool plays a vital role in ensuring the success and efficiency of your work. However, just like any other equipment, your plumbing tools require proper care and maintenance to perform at their best and stand the test of time.

It's important to care for your plumbing tools just as you would any of your vehicles, power tools and the high-end equipment you might have.

Caring for your plumbing tools is not just a chore; it's a responsibility and a testament to your dedication to your craft.

## WHY TOOL CARE MATTERS

Caring for your tools isn't merely about extending their life span; it directly impacts the quality of your work and your reputation as a plumber. Here are some reasons why tool care should be a top priority.

**Performance:** Well-maintained tools operate more smoothly and efficiently, allowing you to work faster and with greater precision. A rusty wrench or a dull cutter can significantly impede your progress and compromise the quality of your workmanship.

**Safety:** Neglected tools are not only less effective but also pose safety hazards. A loose grip on a slippery wrench or a cracked pipe cutter can lead to accidents and injuries, jeopardizing both your well-being and that of your clients.

**Cost-Effectiveness:** Regular maintenance and care can prevent minor issues from escalating into major repairs or replacements, saving you valuable time and money in the long run. Investing in the upkeep of your tools is an investment in your business's sustainability and profitability.

## TIPS FOR TOOL CARE

Now that we understand the importance of tool care, let's explore some practical tips to keep your plumbing tools in optimal condition.

**Cleanliness is Key:** After each use, thoroughly clean your tools to remove any debris, grime or residue that may have accumulated. Use a rag or brush to wipe off dirt, and consider using specialized cleaning solutions for stubborn stains. For metallic tools, applying a light coat of oil can help prevent rust and corrosion.

**Proper Storage:** Store your tools in a dry, well-ventilated area to prevent moisture buildup and rust formation. Organize them in a toolbox or a designated storage rack on your truck or van to minimize clutter and facilitate easy access. Avoid exposing your tools to extreme temperatures or direct sunlight as these can degrade their materials over time.

**Regular Inspection:** Just like your more expensive power tools and work vehicles, you should periodically inspect your tools for signs of wear and damage such as loose handles, dull blades or bent shafts. Replace any worn-out parts or components promptly to maintain optimal performance and safety. Investing in high-quality tools with durable materials can also minimize the need for frequent replacements.

**Sharpening and Lubrication:** Keep cutting tools, such as pipe cutters and blades, sharp and properly lubricated to ensure smooth operation. Use sharpening stones or files to maintain sharp edges and apply lubricating oil or grease to moving parts to reduce friction and wear.

Mechanical  
point repair



LED-based  
UV CIPP

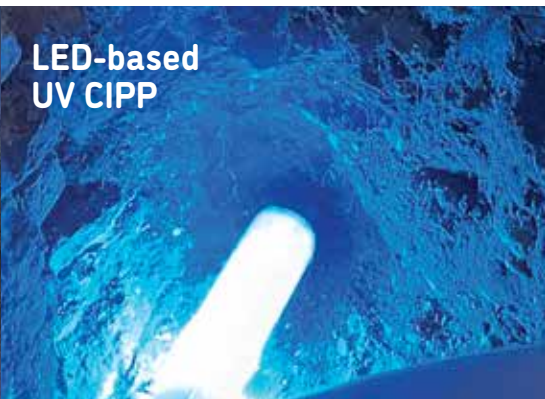

Air-powered  
robotic cutters



**REPAIR  
RELINE  
REINSTATE**



[www.PipelineRT.com](http://www.PipelineRT.com)  
(866) 936-8476

Pipeline rehab  
tools, training  
and support you  
need to help your  
business grow.  
Reach out to our  
sales team for  
more information  
or to request a  
demo.

Be sure to follow manufacturer guidelines and recommendations for sharpening and lubrication procedures.

**Handle With Care:** Treat your tools with respect and avoid using excessive force or rough handling, which can lead to premature wear and damage. Use the right tool for the job and avoid using tools for unintended purposes, as this can cause unnecessary strain and stress on the equipment.

**Educate Yourself:** Stay informed about the proper usage and maintenance of your tools by reading manufacturer manuals, attending training workshops or seeking guidance from experienced professionals. Understanding the intricacies of your tools will enable you to care for them more effectively and prolong their lifespan.

### DEDICATION IS SHOWN

Caring for your plumbing tools is not just a chore; it's a responsibility and a testament to your dedication to your craft. By following these tips and incorporating proper tool care practices into your routine, you can ensure that your tools remain reliable companions throughout your plumbing career.

Remember, a well-maintained tool is not just a tool; it's a reflection of your professionalism and commitment to excellence in every job you undertake.

## SalesMaker Carts

### Escalera Motorized Stair Climbers



**A Helping Hand For Your Boiler & Water Heater Installs!**

- 1200 lb. Capacity
- Climbs both up & down stairs
- Accessories & custom builds available!

[SalesMakerCarts.shop](http://SalesMakerCarts.shop) 800 - 821 - 4140 418 Roberts Ave  
Louisville, KY 40214

## Product Spotlight

Hydronic radiant heating system is clean, efficient and green

By Cody Wiesner

**R**adiant heating is popular among homeowners who value quiet, dependable systems that lower their monthly energy bills and provide cleaner air. It's also a good option for busy HVAC installers and plumbers looking to improve productivity on the job. Crete-Heat, a hydronic floor panel system, installs up to two-thirds faster than other radiant systems, according to company owner Don Regan.

"For contractors, No. 1, it's a huge time-saver," Regan says. "No. 2, for homeowners or the end-user of the building that pays the utilities, 35% of your heat loss is downward loss from the building. That's huge. Crete-Heat is made out of EPS foam, so it maintains twice the rated R-value for life."

Other radiant panel systems traditionally use foam insulation, a vapor barrier and staples or zip ties, all installed in separate steps, but Crete-Heat panels combine all three components into one simplified design.

"And you don't have to staple the tubing down or you don't have to zip-tie it to anything. Basically, put the three panels in and you just lock the tubing, and it's that simple."

This, paired with lightweight, easy transportation across a job site and the ability to be installed by one person, translates to substantial time savings.

Crete-Heat is ideal for indoor, outdoor and winter applications, and suitable for basements, garages, driveways and main floor slab. Each interlocking panel contains EPS

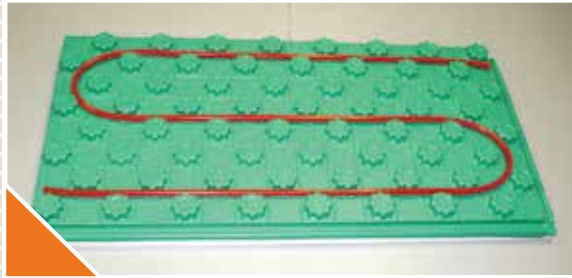

foam with 94% R-value retention and contains several rows of knobs across its surface, which securely holds PEX tubing in between. Concrete is then placed over top to create the thermal flywheel effect radiant heating is known for.

With 25 psi panels on the inside and concrete on the outside, Regan says Crete-Heat is a durable and repair-minimal product.

"Generally speaking, once a concrete is set up and pressure's being maintained, there's never really a need for repair after that."

The company's use of CFC-free, HCFC-free, recyclable EPS makes it an environmentally friendly choice compared to all other forms of styrene. It does not affect air quality and is mold-resistant following ASTM C1338 guidelines. Additionally, Crete-Heat's manufacturing center in Massachusetts offsets almost 500,000 pounds of CO<sub>2</sub> per year thanks to investment in solar power.

Fans of the TV show *This Old House* may have already seen Crete-Heat products in action. While the business began with a homeowner demographic in mind, Regan says Crete-Heat has become especially popular for commercial applications.

"Houses is how we started out, but it just expanded from there."

Crete-Heat products are sold by several dealers across the U.S., including Roth North America. 315-475-0100, [www.roth-america.com](http://www.roth-america.com)

Continued ▶

WHAT'S TRENDING FOR CAMERA INSPECTION?  
**FIND OUT AT PLUMBERMAG.COM**

- FREE Subscriptions
- Email Alerts
- Videos
- Online Exclusives
- E-Newsletters
- Manufacturers/Dealers

# EASY-KLEEN

**PRESSURE SYSTEMS LTD.**  
MANUFACTURER OF HIGH PRESSURE CLEANING EQUIPMENT



SCAN THIS  
TO VIEW OUR  
CATALOG!

## ACCESSORIES

ADD ON HEATER PACK!

EZ0440



- 440,000 BTUs
- Oil Fired Burner

Add hot water to your Sewer Jetter System with a Modular Heater.

Increases speed and efficiency when cleaning out ice or grease.

**"THE BEST VAN PACK IN THE BUSINESS"** - BRAD SIMS, MR. ROOTER

**INSTALL READY FOR PICK UP OR VAN**

Dependable, user-friendly, and cost-effective solution for you to easily clear drains, pipes, and culverts.



**GROUNDHOG JETTER**

◀ The unit featured is a EZJ3512G.

- 35 HP Vanguard Gas Engine
- 12 GPM @ 3500 PSI
- Heavy Duty Triplex Plunger Pump
- 10 Gallon Poly Fuel Tank
- 200 Gallon Poly Water Tank
- 12 V Hose Reel complete with Hose Guides, Super Swivel & Foot Pedal Control
- 300' of 3/8" Jetter Hose
- Remote Control - Optional



SINCE 1982



[easyklean.com](http://easyklean.com)

1-800-315-5533

[sales@easyklean.com](mailto:sales@easyklean.com)



It's your magazine.  
Tell your story.

At *Plumber*, we're looking for plumbing companies with an interesting story to tell.

If you'd like to share your story, send us a note to [news@plumbermag.com](mailto:news@plumbermag.com).

**Plumber**

Trenchless

## LEAD Water Line

Replacement with

## The ACME Pipe Winch



PATENT PENDING

Pull or Split LEAD Water lines, Pull GALVANIZED and COPPER water lines. Also For Trenchless Gas Line Replacement.

- **STRONG** With a line pull of 20,000 lbs.
- **SAFE** The tensioned pulling cable remains within the confines of the winch frame and the access pit
- **ECONOMICAL** The MAX 7/16 pulling cables are reusable
- **STAY IN SPEC** Preserves the original lateral bury depth
- **QUICK COUPLER** Attaches the ACME Pipe Winch to your excavator or backhoe
- **ADAPTABLE SETUPS** The winch rotates 360 deg. and locks in place for a perfect alignment
- **UNIVERSAL FOOT ARRANGEMENT** Pull a water line that is close to a sewer lateral
- **LAND THE PULLING CABLE EVERY TIME** With the ACME Suction Machine

**ACME**  
TRENCHLESS

CALL  
920-376-4222

VISIT  
[WWW.ACMETRENCHLESS.COM](http://WWW.ACMETRENCHLESS.COM)



### Successware field management software update

Successware released its newest quarterly update to the platform aimed at enhancing overall workflow.

Updates in the new release include key improvements in dispatching, such as advanced usability so relevant job and technician information is available in a single location. It also offers power sorting to quickly sort through unscheduled or unassigned jobs to get them on the board immediately. Jobs can be filtered by location so to see where technicians are available, making rescheduling a breeze. Dispatch notices can be tailored to send each technician a list of their jobs for the day, or send a communication by job to the assigned technician, all directly from the dispatch board. The new update also makes it easier to bulk renew customer agreements, helping businesses maintain their consistent revenue by ensuring no agreement gets left behind. **443-873-0499**; [www.successware.com](http://www.successware.com)

### CSI Controls WellZone pressure controllers for well applications

CSI Controls' WellZone pressure controller series for submersible well applications are available in two-wire and three-wire models, which work with any single phase 115/230-volt well pump. They are longer lasting than a standard pressure switch, easy to set up and have a wide range of pressures and pumping differentials. The WellZone controllers eliminate the traditional pressure switch, which is a common system failure point. They provide pump protection against rapid cycling, low pressure, run dry, overpressure, overcurrent and undercurrent. Plus, they are housed in NEMA 4X enclosures, so they can be installed indoors or outdoors. The LCD allows for quick view of the system pressure, run status, hours run and pump cycles. The rotary button provides the user with a simple navigation method through the menu and program settings. **218-847-1317**; [www.csicontrols.com](http://www.csicontrols.com)



### FieldEdge by Xplor MarketingEdge marketing automation tool

FieldEdge by Xplor, an all-in-one software platform for home contracting businesses, has announced a new digital marketing automation tool, MarketingEdge. With audience targeting, lead management, email marketing and personalized advertising, MarketingEdge is designed to help HVAC, plumbing, electrical, locksmith and appliance repair businesses present a professional brand image, upsell their services to existing customers, and attract new prospects more easily. The digital marketing tool enables automated marketing campaigns with prebuilt email, text and landing pages, to speed campaign creation, and offers unlimited texts and emails. It also can do smart audience segmentation, for sending more authentic messages based on customer behaviors and preferences, and real-time tracking and analytics, for viewing email open, engagement and conversion rates and easily assessing how a campaign is performing. **800-226-7529**; [www.fieldedge.com/marketingedge](http://www.fieldedge.com/marketingedge)

*Send us your plumbing product news. Email new plumbing product news, photos, and videos to [editor@plumbermag.com](mailto:editor@plumbermag.com).*

**JOIN**  
THE CONVERSATION.  
THE CAMARADERIE.  
THE COMMUNITY.

**Plumber**

- [facebook.com/PlumberMag](https://facebook.com/PlumberMag)
- [twitter.com/PlumberMag](https://twitter.com/PlumberMag)
- [youtube.com/PlumberMagazine](https://youtube.com/PlumberMagazine)
- [linkedin.com/company/plumber-magazine](https://linkedin.com/company/plumber-magazine)



# FEATURED IN AN ARTICLE?

**MAKE THE  
MOST OF IT!**

Reprints available:  
Hard copy color reprints  
Electronic reprints

Visit [plumbermag.com/order/reprint](http://plumbermag.com/order/reprint)  
for articles and pricing



**PICOTE**

**XPRESS COATING SYSTEM**

**NEW SYSTEM FOR COATING 1/4 - 12" PIPES**

- AS LITTLE AS ONE HOUR CURE TIME
- BATTERY OPERATED PUMP SYSTEM
- NEW SUPERIOR RESIN MIXED AT END OF DELIVERY HOSE
- REUSABLE HOSE ELIMINATES WASTE AND SETUP TIME
- USE IN CONJUNCTION WITH PICOTE MILLERS
- MAX RANGE OF 132 FEET
- NOW AVAILABLE TO ORDER!

864-940-0088  
sales@picotesolutions.com  
PICOTEGROUP.COM/RESELLERS  
PICOTEINSTITUTE.COM

estimate better.

SEE A DEMO TODAY

visit [estimatebetter.com](http://estimatebetter.com) to learn more!

**FastPIPE**  
ESTIMATING SOFTWARE

Searching for More?

More news at  
[PlumberMag.com/featured](http://PlumberMag.com/featured)

**Plumber**

# Keep it coming each month!

# Don't miss:

» Company Profiles

» First Responders

» On the Road

» In The Shop

# Plumber



**FREE SUBSCRIPTION** (US, Canada & Mexico Only)

Please tell us about yourself, so we can better serve you.

**Start/Renew my subscription to Plumber Magazine.**

**Signature (required)** \_\_\_\_\_

**Date** \_\_\_\_\_

**Print Name** \_\_\_\_\_

**Title** \_\_\_\_\_

**Company or Facility** \_\_\_\_\_

**Mailing Address** \_\_\_\_\_

**City** \_\_\_\_\_

**State** \_\_\_\_\_ **Zip** \_\_\_\_\_

**Phone** \_\_\_\_\_ **Fax** \_\_\_\_\_

**Email** \_\_\_\_\_

**Also send a FREE subscription to:**

**Coworker's Name** \_\_\_\_\_

**Title** \_\_\_\_\_

**Email** \_\_\_\_\_

COLE Publishing Inc., PO Box 2707, Eagle River, WI 54521  
plumbermag.com • Ph: 800.257.7222 • Fax: 715.350.8456

#### WHAT IS YOUR PRIMARY SERVICE?

- Plumbing/Heating/Cooling  Rehabilitation/Relining/Bursting  
 Sewer/Drain Cleaning  Dealer/Distributor/Manufacturer  
 Septic System Installation/Repair  Consulting/Engineering  
 Other \_\_\_\_\_

#### WHAT BEST DESCRIBES YOUR PRIMARY JOB FUNCTION?

- President/CEO/Owner  Management/Supervisor  
 Operator/Technician  Other \_\_\_\_\_

#### HOW MANY EMPLOYEES DO YOU SUPERVISE OR WORK WITH AT YOUR FACILITY?

- 1-3  4-9  10-19  20+

#### HOW MANY VEHICLES DO YOU CURRENTLY HAVE IN SERVICE?

- 1-5  6-10  11-15  16-20  21+

#### WHAT IS THE APPROXIMATE POPULATION OF THE AREA IN WHICH YOU PROVIDE SERVICE?

- 1-10,000  10,001-50,000  50,001-100,000  
 100,001-200,000  200,001-500,000  500,001+

#### WHAT IS YOUR ANNUAL EQUIPMENT BUDGET?

- \$1-\$50K  \$51K-\$75K  \$76K-\$150K  \$151K-\$250K  
 \$251K-\$350K  \$350K +

#### WHAT SERVICES DO YOU PERFORM ON A REGULAR BASIS?

- Plumbing Maintenance/Repair  Sewer/Drain Cleaning  
 New Construction - Commercial  Pipe Bursting  
 New Construction - Residential  HVAC  TV Inspection  
 Location/Leak Detection  Septic System Installation  
 Septic Tank Pumping  Other \_\_\_\_\_



**June 10-12**

**Women in the Mechanical Industry 2024 Conference**, Renaissance Cleveland Hotel. Visit [mcaa.org/events](https://mcaa.org/events)

**June 10-13**

**AWWA Annual Conference & Exposition**, Anaheim Convention Center, California. Visit <https://events.awwa.org>

**June 16-18**

**Canadian Institute of Plumbing & Heating Annual Business Conference**, Delta Grand Okanagan Resort, Kelowna, British Columbia. Visit [www.ciph.com](http://www.ciph.com)

**June 26-27**

**Houston Build Expo**, NRG Park Center (Hall E1/E3). Houston. Visit [buildexpousa.com/houston-build-expo/](https://buildexpousa.com/houston-build-expo/)

**July 31 - Aug. 1**

**Atlanta Build Expo**, Cobb Galleria Centre (Halls C & D). Visit [buildexpousa.com/atlanta-build-expo/](https://buildexpousa.com/atlanta-build-expo/)

**Aug. 7-9**

**Safety 2024 Professional Development Conference & Exposition**, Colorado Convention Center, Denver. Visit [safety.assp.org](https://safety.assp.org)

**Aug. 28-29**

**Los Angeles Build Expo**, Los Angeles Convention Center (West Hall A). Visit [buildexpousa.com/los-angeles-build-expo/](https://buildexpousa.com/los-angeles-build-expo/)

**Sept. 22-26**

**95th Annual International Association of Plumbing and Mechanical Officials Conference**, Planet Hollywood, Las Vegas. Visit [iapmo.org](https://iapmo.org)

**Sept. 24-26**

**WaterSmart Innovations**, South Point Hotel and Conference Center, Las Vegas. Visit [awwa.org/events-education/watersmart-innovations](https://awwa.org/events-education/watersmart-innovations)

**Sept. 25-26**

**South Florida Build Expo**, Broward County Convention Center (Hall C), Fort Lauderdale, Florida. Visit [buildexpousa.com/south-florida/](https://buildexpousa.com/south-florida/)

Plumber invites organizations and associations to submit details about upcoming industry trade shows and conferences for our calendar of events. [editor@plumbermag.com](mailto:editor@plumbermag.com).

## Do You Need the BIGGEST, BADDEST Pipe Extractors Available?



TRY **WALTON**™ **"REPS"**

**Pipe, Stud & Screw Extractors**

### TO EASILY REMOVE...

- All classes of pipe sizes from 1/8" to 2"
- Stud and screw sizes from 3/8" to 3 1/2"

Available as sets or individual pieces.

"REPS" remove broken pipe fittings quickly and easily – without costly damage to mating fittings.



Forget reaming and other makeshift methods. Obtain a strong four-point grip without hammering or pounding to pull out broken pipes, studs and screws with ease.



Phone: (860) 523-5231  
[sales@waltontools.com](mailto:sales@waltontools.com)

Tapping into good ideas for over 110 years.

[www.WaltonTools.com](http://www.WaltonTools.com)

## Great Price

We also carry great pricing on:

- Diablo Reciprocating saw blades
- Drill Bits
- Abrasive wheels
- Fast processing and shipping
- 100% Satisfaction Guarantee



17 Piece Diablo Hole Saw Kits

[DiscountSawBlade.com](https://DiscountSawBlade.com)  
A Qescorp, Inc. Site

Call 888 641 9798



This is what it would look like if we printed [plumbermag.com](https://plumbermag.com) thousands of stories, products and ideas

Get access to everything we can't fit in the magazine. Additional stories, videos, news briefs and other great information that lets you get the most out of *Plumber*.

[www.plumbermag.com](https://www.plumbermag.com)

## General Pipe Cleaners promotes Angela Grieb to national sales manager

General Pipe Cleaners has promoted Angela Grieb to national sales manager. In her new role, Grieb will manage, train and support General Pipe Cleaners' network of independent sales reps, provide customer support and interface with wholesalers, distributors, end users and influencers. She joined the company in 2005 as the executive assistant. During her 19-year career at General Pipe Cleaners, she has performed many roles, including sales support, marketing support, human relations and assistant national sales manager.



## Zoeller names Bill Zoeller as chief executive officer

Zoeller Co. announced that Bill Zoeller became CEO May 1. Zoeller's board of directors, with the support of executive search firm Kensington International, selected Zoeller, previously chief operating officer, to lead the company as CEO upon the retirement of John Zoeller, who has served for 22 years.



"As the chief operating officer at Zoeller Company, Bill Zoeller has shepherded the company through several acquisitions, significant growth and the COVID-19 pandemic, cementing the company's position as a leader in the water solutions industry," says Christopher Carmicle, chair of the board at Zoeller Co. Prior to this role, Bill Zoeller served as the president of Louisville Operations and director of risk management of Zoeller Co. Before joining Zoeller Company in 2011, Zoeller spent more than a decade at LG&E and KU Energy and KPMG.

## Taco begins expansion project on Massachusetts plant

Taco expansion of its Fall River, Massachusetts, plant is underway. The over \$20 million project greatly enhances and expands the manufacturer's ability to build larger tanks, heat exchangers and a wide range of other products, while also enabling them to add capacity and reduce lead times. Taco Comfort Solutions, based in Cranston, Rhode Island, began making plans for the plant expansion more than a decade ago. Groundbreaking began in early September 2023 and the project is expected to take about 18 months to complete.

## RIDGID celebrates 25 years in press technology

RIDGID, a part of Emerson's professional tools portfolio, is celebrating 25 years in press technology. The brand first introduced press technology to North America in 1999 and has continued to help professional tradespeople utilize the platform to drive job site efficiencies. RIDGID offers a product portfolio of innovative solutions that help tradesmen and women achieve fast, secure and flame-free connections.

## Plastics Pipe Institute publishes new technical document

A new technical document that addresses the critical differences between cross linked PEX tubing systems with polybutylene systems has been published by the Plastics Pipe Institute. The initiative was deemed necessary to eliminate any confusion between the two products because of problems associated with polybutylene, which was discontinued. Prepared by PPI's Building and Construction Division, "PPI TN-31 Differences Between Crosslinked Polyethylene and Polybutylene Piping Systems for Potable Water Plumbing Applications" discusses the advantages of modern PEX tubing and fittings as compared with PB tubing and fittings, which were last sold in the U.S. during the late 1990s.

## CUES software recognized as Esri Cornerstone Partner

CUES' GraniteNet Asset Inspection/Decision Support Software was recognized as an Esri Cornerstone Partner at the 2024 ESRI Partner Conference on March 10-11 in Palm Springs, California, for 20 years of commitment to Esri and ArcGIS technology. Developed by CUES in 2004, the inclusion of GIS spatial mapping to asset infrastructure data is now used by over 1,000 municipal utilities and contractors.

## A. O. Smith appoints Stephen Shafer to president and COO

A. O. Smith has appointed Stephen Shafer as president and chief operating officer. In this role, Shafer will lead the company's global business units, including operations, engineering and IT. Most recently, he served as president of the Automotive and Aerospace Solutions Division for 3M Company. Prior to 3M, Steve worked for McKinsey & Company and Ford Motor Company holding various roles focusing on manufacturing, supply chain and operational improvement.



Continued ▶

**BUSINESS OPPORTUNITIES**

www.RooterMan.com. Franchises available with low flat fee. New concept. Visit web site or call 1-800-700-8062. (LBM)

**SERVICE & REPAIRS**

**PIPE INSPECTION - CAMERA WHEELS WORN OUT?** I can re-grit them for you. Call Jerry 714-697-8697 or visit www.cuaclaws.com. (LBM)

LIST YOUR EQUIPMENT IN THE PAGES OF **PLUMBER!**

plumbermag.com/classifieds/place-ad

**Plumber**  
It's your magazine. Tell your story.  
Send your ideas to editor@plumbermag.com or call 800.257.7222

**SEE WHAT'S INSIDE**  
**Plumber**  
PlumberMag.com

GET **EMAIL NEWS ALERTS** FOR **Plumber**  
Go to [plumbermag.com/alerts](http://plumbermag.com/alerts) and get started today!

**RAT OUT YOUR ROOT PROBLEMS**

- Interchangeable heads.
- Uniquely designed to make short work of big sewer line headaches.
- Use the chain rotor for major obstructions and the cable rotor for less aggressive problems.

3/8", 1/2", 1" nozzles come in kit form.

**ROOT RAT NOZZLES**  
Patented Made in USA **330.874.4300** www.rootrat.net

**AMERICAN JETTER.COM**

**Up to 67% MORE EFFICIENT**

51T Trailer Jetter Hot or Cold  
18 GPM @ 5000 PSI / 20 GPM @ 4000 PSI  
76 HP Kohler EFI\*

58 Trailer Jetter Hot or Cold  
10 GPM @ 4000 PSI  
38 HP Kohler EFI\*

\*FREE Shipping/Delivery

**866-944-3569**

**Cua Claws**

A Simple Solution for Slippery PVC Pipe - **The Right Wheels**  
It's all in our grit!

CALL JERRY AT 714-697-8697  
[www.cuaclaws.com](http://www.cuaclaws.com)

**Superior SMOKE**

Find Plumbing Leaks & Sources of Odors

MADE IN USA

Fast • Inexpensive • Easy

Battery Powered 5E FLEX with 12-24V Battery Adapter

[SuperiorSignal.com/PLFLEX](http://SuperiorSignal.com/PLFLEX)

**Septic-Scrub**

Used by More Professional Pumpers to Increase Their Business

- Backed By Science
- Proven with Experience
- Many Satisfied Homeowners

Septic-Scrub™ is a superior product for the maintenance and restoration of septic system drainfields. Customers appreciate that it is environmentally safe, contains no organic chemicals and does not produce any toxic by-products. Most importantly, **Septic-Scrub works**. It breaks down sulfide buildup in the biomat and soil to allow for better water absorption. Learn more about Septic-Scrub at [www.arcan.com](http://www.arcan.com).

For information on increasing sales and providing a valuable service to your customers, call Arcan Enterprises at **888-35ARCAN (352-7226)**

**arcan**  
P.O. Box 31057 • Clarksville, TN 37040

**MORE?!**

Plumber

More Stories at [PlumberMag.com/featured](http://PlumberMag.com/featured)  
See what's not in print!

OUR BEST SELLING DRAIN LINE JETTER!

**HOTJET II**  
10GPM @ 4000 PSI • 35HP VANGUARD  
Cleans VCP, CPVC, ABS, PP, PVC, S&W

FREE 30 DAY MONEY BACK GUARANTEE

OVER 30 YEARS BUILDING QUALITY EQUIPMENT

**HotJetusa**  
**1-800-624-8186**  
[WWW.HOTJETUSA.COM](http://WWW.HOTJETUSA.COM)

PRICES SUBJECT TO CHANGE - CALL FOR CURRENT PRICING

## Viega announces Andreas Reger as new CEO

Viega has appointed Andreas Reger as its new president and chief executive officer. Reger will replace Markus Brettschneider, who was recently appointed as the new global CEO for Viega Group. This strategic move follows the decision of current Global CEO Claus Holst-Gydesen to move to Viega's supervisory board, after 14 years of leadership, with the last 10 years as global CEO.

## IAPMO publishes manual of recommended construction practices for potable water

The International Association of Plumbing and Mechanical Officials and the Construction Practices for Potable Water Task Group have released the publication titled the *Manual of Recommended Construction Practices for Potable Water*. This manual provides education and guidance to help plumbing professionals responsible for the design, construction and commissioning of water systems to reduce the potential of contaminating plumbing systems during construction. On Sept. 15, 2021, IAPMO initiated the task group to create a manual to provide code enhanced and adoptable language for construction use, related to potable water piping systems and water safety management during the construction phase. The task group consisted of more than 30 industry experts from across the nation, focused on actionable guidance and construction best practices surrounding potable water.

## NIBCO promotes Joe Choflet to VP, sales and marketing

NIBCO has promoted Joe Choflet to vice president, sales and marketing. In his new role, Choflet will continue to lead wholesale, retail, specialty and international sales. He will now oversee product marketing for plastic and metal fittings and valves. Choflet will continue to report to Ashley Martin, president and COO of NIBCO.



## Oatey acquires Sweden-based Aktibolaget Durgo

Oatey has acquired Aktibolaget Durgo, a specialty developer and manufacturer of air admittance valves and other pressure regulating valves based in Stockholm, Sweden. For more than 100 years, the company has also embraced state-of-the-art technology to continue to achieve high standards of quality and safety.

## Bradford White donates heat pump water heaters

Bradford White continues its commitment to support training the workforce of the future by providing strategic in-kind grant funding to the Center for Employment Training, a national nonprofit technical training school. The grant, which stems from Bradford White's charitable giving initiative, Industry Forward, includes the purchase of nine 50-gallon AeroTherm heat pump water heaters, which will be used at nine CET training centers across northern and Southern California for their training programs.



## Legend Valve opens Texas distribution center

Michigan-based Legend Valve opened its new distribution center in Stafford, Texas. The new warehouse substantially increases its distribution footprint for customers in the growing Southern U.S. The new facility will allow two-day-or-less delivery for 96% of customers in the continental United States. The facility will also offer local wholesalers easy access to a will-call service desk, further allowing customers to reduce their inventory-carrying costs. [P](#)



Send us your plumbing industry news. Email personnel, business acquisitions and related plumbing news, photos and videos to [editor@plumbermag.com](mailto:editor@plumbermag.com).



Get more news, information, and features with our exclusive online content.

[plumbermag.com/featured](http://plumbermag.com/featured)



The preferred lateral & vertical rehab solution.

**A FRESH  
LOOK.**

---

**A NEW  
ATTITUDE.**

---

**MAXLINERUSA.COM**



Field tested and proven by commercial plumbers, for over 20 years!

- Equipment
- Liners
- Resins



**GUYS SWEAR  
BY THIS,  
NOT AT IT.**

“I call it my ‘workhorse’...  
Speedroooter 92 means  
service with a capital ‘S!’”

Carl Helt  
Helt Plumbing

“Smoother, cleaner,  
quieter and more  
reliable.”

James Capelli,  
California plumber

“...rugged reliability,  
optimal control  
and ease-of-use.”

Larry Linn,  
Linn's Plumbing

## Speedroooter 92®

You'll be amazed at the performance gains from Flexicore® Cable, rugged “real” steel drums and the convenient V-Belt Stair Climbers amongst other time-tested features. The General Speedroooter 92—you'll swear by it, not at it.

For more information, call the Drain Brains® at 800-245-6200, or visit [drainbrain.com/speedroooter-92/](https://drainbrain.com/speedroooter-92/)



© 2024 General Wire Spring

**The toughest tools down the line.™** *General*  
PIPE CLEANERS